

2019 STOCK CATALOG





HAHN-MASON
AIR SYSTEMS

Home Office & Warehouse

Charlotte, NC

4901 Dwight Evans Road
Suite 120
Charlotte, NC 28217
[704] 523-5000 *phone*
[704] 523-5171 *fax*
[704] 523-5344 *warehouse phone*
[704] 523-5880 *warehouse fax*

Regional Offices

Raleigh, NC

1001 Wade Ave.
Suite 205
Raleigh, NC 27605
[919] 834-9230 *phone*
[919] 831-9714 *fax*

Asheville, NC

1796 Hendersonville Road
Suite S
Asheville, NC 28803
[828] 277-1544 *phone*
[828] 277-1564 *fax*

Charleston, SC

128 S. Main Street
Suite 1
Summerville, SC 29483
[843] 871-2493 *phone*
[843] 871-2510 *fax*

Columbia, SC

2330 Main Street
Columbia, SC 29201
[803] 978-2038 *phone*
[803] 978-2039 *fax*

Greensboro, NC

2915 Baltic Avenue
Greensboro, NC 27406
[336] 272-9198 *phone*
[336] 272-9299 *fax*

Greenville, SC

112 South Main Street
Suite E
Greer, SC 29651
[864] 655-5980 *phone*
[864] 655-5982 *fax*

Hickory, NC

511 S. Main Ave.
Newton, NC 28658
[828] 726-2412 *phone*
[828] 994-4249 *fax*

www.hahnmason.com



Hahn-Mason Air Systems, Inc is a manufacturers' representative firm serving the commercial and industrial HVAC marketplace in the Carolinas. Since 1952, Hahn-Mason has developed a reputation for providing high quality equipment with a superior level of customer service.

Hahn-Mason Air Systems, Inc. represents the products of quality manufacturers ranging from grilles and diffusers to VAV terminal units; sheet metal products to specialty air handling equipment; industrial ventilation to laboratory and critical airflow control. Our sales engineers and support staff are equipped to handle your needs.

We thank you for your business and look forward to serving you in the future.

LIST OF MANUFACTURERS

Absolutaire	Kitchen and Commercial Make-Up Air Units
Aerovent, Flakt, Inc.	Industrial Axial and Centrifugal Fans, Roof Ventilators, Air Makeup Units, Controllable Pitch Vaneaxial Fans
Air Maid by Interzone**	Kitchen/Grease Exhaust Solutions
Antec by Price** (Formerly Price Critical Controls)	Laboratory, Healthcare, and Pressure sensitive critical environmental air flow control
Armstrong International	Steam, Gas, and Electric Humidifiers
Barco	Venturi Flowmeter Systems
Berko/Qmark*	Electric Space Heating Products
Chamberlin Rubber Company, Inc.	Stainless Steel Assemblies & Kits
Coil Company	Commercial and Industrial water, steam & DX coils
Cosatron**	Air Purification Systems
Denlar	Residential Kitchen Hoods with Integral Fire Suppression
Ductmate Industries*	Access Doors for Round, Oval, Rectangular Duct, Duct Sealer
Eaton**	Adjustable frequency drives (VFDs) and motor starters
Envirco	HEPA Fan Filter Units
Grease Master	Kitchen Exhaust Hood Systems
Honeywell Analytics*	Gas Detection Systems
Imperial Metals*	Sheet Metal Curbs and Equipment Rails
Karp Company*	Access Doors – Standard and Fire Rated Access Doors
KE Fibertec	Textile based Ventilation Equipment
Kinetics Noise Control*	Commercial/Industrial duct silencers, vibration & seismic isolation
Loren Cook Company*	Commercial and Industrial Fans, Gravity Ventilators, Energy Recovery Ventilators
Malco Tools*	Sheet Metal Tools
Metal-Fab, Inc.	Boiler, Water Heater, Engine Exhaust and Kitchen UL Grease Duct Ventilation Systems
Nailor Industries *	Air distribution, terminal units, fan coil units, fire/smoke/control dampers, louvers
Nederman	Vehicle Exhaust, Dust & Frame Collections, and Speciality Exhaust
Panasonic	Fans, Mini-Splits, & VRF/Applied Split Systems
Patterson Fan	High volume low speed (HVLS) fans Dock and Door/ Warehouse Fans
Precision Air Products Company	Cleanroom and hospital OR integrated ceiling diffuser systems
Reflect-O-Ray/CRC	Gas Fired Infrared Radiant Heaters - Dry Tube System
Reznor*	Gas/Electric make-up air & DOAS units
Rickard Air Diffusion*	VAV Diffusers – Pneumatic, Electronic, Thermally Powered
Roof Products Systems*	Pipe Portals
Royal Metal Products*	Sheet Metal Products
Safe Air/Dowco, Inc.	Fire / Smoke / Control / Industrial Dampers, Access Doors, Louvers
Seiho	Specialty Air Distribution-RoundRegister™, SpotDiffuser™, VentLouver™
Semco*	Spiral and specialty duct, Engineered panels and housing, Sound Alternators, and Chilled Beam Products
Seresco, Inc.	Indoor Pool Dehumidification and Dedicated 100% Outside Air Units
Specified Controls*	VAV diffusers, Zone Control Dampers and VVT Systems
Spunstrand, Inc.	Fiberglass, Reinforced Plastic Duct
Systemair*	Parking structure and Residential ventilation solutions
Thermal Corporation	Custom air handling equipment
Ventaire	Vehicle Exhaust Fume Removal System, Dust Collection System
Williams	Fan Coil Units



* In the Charlotte Warehouse

** New Manufacturers

TERMS OF SALE

1. **Prices listed are selling prices.**
2. **Terms of payment are net 30 days from date of invoice.**
3. **Items to be returned to stock are subject to a 20% restocking charge.**
4. **No sales taxes is included in the prices listed in this catalog.**
5. **All shipments are F.O.B. our Charlotte warehouse, freight prepaid and added to invoice.**
6. **Warranties: Standard manufacturer warranties to apply.**
7. **Pricing is subject to change without notice.**
8. **Title to all materials shall remain the sellers until the purchase price thereof is paid in full.**
9. **Claims:**

The responsibility of Hahn-Mason Air Systems, Inc. ceases upon delivery of materials in good order to the carrier. Any claims for damages, shortages, or losses in transit must be filed by the customer against the transportation company once the material is received. Claims of shortage will not be considered unless made within 30 days after receipt of goods.

10. Return policy:

- ▶ Material must be returned within 90 days of purchase.
- ▶ Return authorization and shipping ticket or copy of HMI invoice to be included with return.
- ▶ Returns will be subject to a 20% restocking fee.
- ▶ Only stock items will be accepted for return here. If non-stock items are returned without authorization the customer will be responsible for the return freight. No credit will be issued.

*** All credit card transactions subject to a 5% surcharge.**

TABLE OF CONTENTS

List of Product Manufacturers	2
Terms & Conditions	3
Air Distribution Cross Reference.....	4
NAILOR AIR DISTRIBUTION	
Supply Grilles & Registers	5
Return Grilles & Door Grilles	6
Perforated Supply Diffusers	7
Square Ceiling / Plaque Supply Diffusers	8
Round, Square Ceiling Diffusers & OBDs	9
Perforated Return & Eggcrate Diffusers	10
Lay-in Filtered Grilles & Plaster Frames	11
Plenum Slot Diffusers and IDCO dampers	12
Linear Slot Diffusers	12
Rickard Thermo-Disc Ceiling Diffusers	13
NAILOR AIR TERMINAL UNITS	
Single Duct VAV Boxes Hot Water Coils.....	14
Single Duct VAV Boxes (Accessories) Hot Water Coils	15
Fan Powered Terminal Units with Electric Heat	16-17
Specified Controls Control Dampers	18
System Sensor Smoke Detectors	18
3M Fire Barrier Wrap and Fire Pillow.....	19
ACCESS DOORS	
Ductmate Round, Oval, & Rectangular Duct	20
Ductmate High Temp Door	20
Karp Sheetrock Access Doors	20
Karp Fire Rated Access Doors	20
DAMPERS	
Ceiling Radiation Dampers	21
Dynamic Fire Dampers	21
KINETICS NOISE CONTROL	
Spring Isolators	22
LOREN COOK EXHAUST FANS	
Loren Cook Cross Reference	23
Ceiling Exhausters	24-25
Ceiling Exhauster Accessories	26
Centrifugal Roof Exhausters (direct drive)	27
Centrifugal Roof Exhausters (belt drive)	28-29
LOUVERS/RAILS/CURBS/PIPE PORTALS	
Gravity Ventilators	30
Roof Caps	31
Equipment Rails and Roof Curbs	32
Extruded Aluminum Louvers and Brick Vents, Back draft dampers	33
Roof Products System Pipe Portals	34-35
SPIRAL DUCT & FITTINGS	
Spiral, Reducers, Saddle Taps.....	36
90° Elbows, 45° Elbows, Dampers.....	37
Couplings, Plugs, Bell Mouths.....	38
Spiral Grilles and Gripple Hanging Cable	39
FLEX AND TAPE	
Royal Metals R-6 Insulated Flex, Duct Brace	40
ATCO R-6 Uninsulated Flex/ UL Label Tape	41
SHEET METAL ITEMS	
Spin Ins, Start Collars.....	42
Stick On Fittings, Wyes, Caps	43
Snap lock pipe, Elbows.....	44
Square to Round Transitions.....	44
Vent Top Flashing	45
High Efficiency Take offs, Damper Blades	45
Miscellaneous Items	45
Malco Tools.....	46
DUCT SEALER/DUCT WRAP	
Ductmate Duct Sealer.....	47
Knauff Duct Wrap	47
BERKO HEATERS	
Wall Heaters	48
Unit Heaters	49
MEASURING INSTRUMENTS	
Honeywell CO Gas Detector, Accessories	50
Test Kits	50
REZNOR GAS FIRED HEATERS	51
Discontinued Warehouse Items	52



AIR DISTRIBUTION CROSS-REFERENCE

Nailor	Metal-Aire	Price	Titus	Tuttle & Bailey	Carnes
61DV	V4004	520S	300RS	T64	RSDBV
6145H	RH	530L	350RL	T70D	RSABH
4320CB	7000	PDC	PCS	PV	SPFB
61DGD	DGDF	STG/BF	T700L-AF	A980WF	RGCAD
4320L	7500	PDF	PAS	PP	SPAB
4360	7600R	PDDR	PAR	PR	SPRB
4302	SPRTB	PFRF	PXP	PTL	SPHB
RNS	5700	SCD	TMS	1200/1300	SFTB
6500	5500	SMD	TDC	MSR	SKTA
UNI	5850	SPD	OMNI	T-1100	SFPA
61EC	CC1	80	50F	CRE	RAEAC
DFA	TBPF	PFS	TRM	SMF	KXFAA
61FBL45	SRAF	530FF	350RLF	T70DFB	RSABD
61FEL	CC1S-FB-6	80FF	50FF	CB8500FB	RAPAF
61FPL	RP-FB	10FLB	8RF	PGFB	RSFA
5710I	PDI10	TBD410	TBDI	SVPSI-075	DARB-B-R
5000	6600	SDS	ML	6X(1,2,5)	CH
5575	N/A	TBD2	TBD-FR	N/A	5575WB
4113	SPRTBFRS	10FR	7600-FRS	N/A	N/A
P3001	500/400TH	SPV	PESV	SDVP	AVCC-CX
D3001	500/400TH	SDV	DESV	SDVD	AVCC
P3230	400DD	DPS	PEDV w/ATT.	DDVP	ADCD-CF
35NE	400FVI	FDV	DTQP	FPV	ASEG
35SE	400FCI	FDC	DTQS	FPC	ACFG
5075	6575	SDS75	ML38	62	CHCB
5010	6510	SDS100	ML39	72	CHFB
5375 I	6075BPI	SDAI75	MPI38	DPI62	CXPA6-1
5310 I	6100BPI	SDAI10	MPI39	DPT72	CXPA8-1
4275	D3	VCR	AG-75	RON	KXMB
RNR	3100	RCDE	TMR	P3	SSEA

This Cross Reference Guide is for your assistance when selecting products with competitors' specifications and models. HMI is only making a recommendation and will not assume any liability for making this recommendation.

Size (inches)	CFM @ NC 30	Net Each	With OBD
6 x 6	220	\$16.00	\$27.00
8 x 4	220	\$16.00	\$27.00
8 x 6	270	\$16.00	\$27.00
8 x 8	350	\$18.00	\$29.00
10 x 4	220	\$18.00	\$30.00
10 x 6	340	\$18.00	\$33.00
10 x 8	450	\$18.00	\$33.00
10 x 10	550	\$19.00	\$33.00
12 x 4	270	\$18.00	\$32.00
12 x 6	400	\$18.00	\$32.00
12 x 8	520	\$19.00	\$33.00
12 x 10	675	\$21.00	\$35.00
12 x 12	720	\$25.00	\$39.00
14 x 6	450	\$19.00	\$34.00
14 x 8	525	\$21.00	\$35.00
14 x 10	720	\$28.00	\$43.00
14 x 12	800	\$28.00	\$44.00
14 x 14	920	\$30.00	\$48.00
16 x 6	540	\$21.00	\$37.00
16 x 8	640	\$25.00	\$42.00
16 x 10	870	\$28.00	\$45.00
16 x 12	920	\$30.00	\$47.00
18 x 6	525	\$26.00	\$43.00
18 x 8	720	\$28.00	\$46.00
18 x 10	900	\$30.00	\$49.00
18 x 12	1050	\$33.00	\$53.00
20 x 6	675	\$28.00	\$45.00
20 x 8	800	\$29.00	\$47.00
20 x 10	920	\$33.00	\$53.00
24 x 6	720	\$30.00	\$50.00
24 x 8	920	\$33.00	\$54.00
24 x 10	1170	\$37.00	\$58.00
24 x 12	1320	\$38.00	\$61.00
30 x 8	1230	\$39.00	\$69.00
30 x 10	1320	\$44.00	\$72.00
30 x 12	1624	\$49.00	\$85.00
36 x 8	1320	\$49.00	\$85.00
36 x 10	1624	\$54.00	\$92.00
36 x 12	1953	\$59.00	\$99.00

Supply Registers/Grilles: Model 61DV

- Double deflection adjustable type
- Vertical front blades, horizontal rear blades
- Corrosion-resistant steel construction
- 1/4" border with countersunk screws holes
- Appliance white baked enamel finish
- Optional opposed blade damper

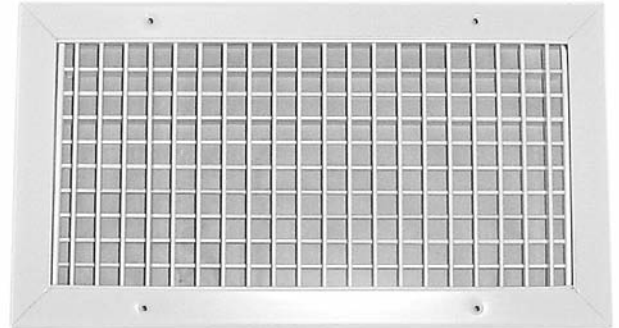

Model 61DV (Vertical Front Blades)

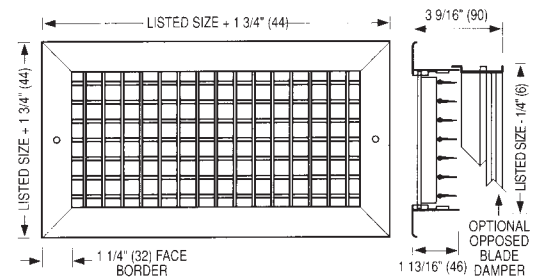

****Spiral Duct Mounted Grilles On Page 39****

RETURN GRILLES

Return Registers/Grilles: Model 6145H Surface Mount

- ▶ Single 45° fixed horizontal blades spaced at 3/4" centers
- ▶ Corrosion-resistant steel construction
- ▶ Appliance white baked enamel finish
- ▶ Optional opposed blade damper
- ▶ Surface mount frame with countersunk screw holes (shown below) or Lay-In frame

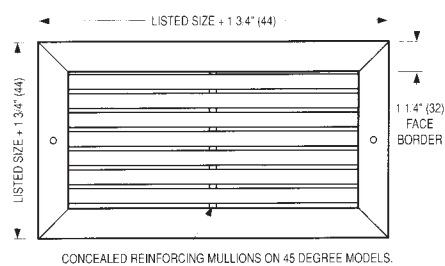

Model 6145H

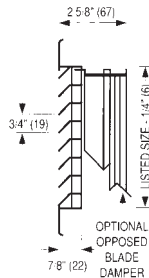

Size (inches)	CFM @ NC 30	Net Each	With OBD
6 x 6	170	\$11.00	\$22.00
8 x 8	300	\$14.00	\$25.00
10 x 6	280	\$14.00	\$29.00
10 x 8	350	\$14.00	\$29.00
10 x 10	450	\$16.00	\$30.00
12 x 6	300	\$14.00	\$28.00
12 x 8	430	\$16.00	\$30.00
12 x 10	518	\$16.00	\$30.00
12 x 12	620	\$17.00	\$31.00
14 x 8	455	\$17.00	\$31.00
14 x 10	620	\$17.00	\$32.00
14 x 12	720	\$20.00	\$36.00
14 x 14	868	\$21.00	\$39.00
16 x 8	518	\$17.00	\$34.00
16 x 12	860	\$21.00	\$38.00
16 x 16	1066	\$25.00	N/A
18 x 12	900	\$21.00	\$41.00
18 x 18	1350	\$33.00	N/A
20 x 8	800	\$22.00	\$40.00
20 x 12	1012	\$26.00	N/A
20 x 20	1566	\$37.00	N/A
24 x 6	600	\$21.00	\$41.00
24 x 8	840	\$21.00	\$42.00
24 x 12	1185	\$27.00	\$50.00
24 x 16	1500	\$33.00	N/A
24 x 18	1566	\$37.00	N/A
24 x 24	2200	\$49.00	N/A
30 x 12	1475	\$33.00	\$69.00
30 x 16	1900	\$39.00	N/A
30 x 24	2600	\$59.00	N/A
30 x 30	3200	\$71.00	N/A
36 x 18	2375	\$52.00	N/A
36 x 24	3160	\$69.00	N/A
36 x 36	4345	\$117.00	N/A
48 x 24	3900	\$85.00	N/A
48 x 30	3900	\$109.00	N/A
48 x 48	7015	\$216.00	N/A

Return Registers/Grilles: Model 6145H Lay-In

Size (inches)	Net Each	With OBD
24 x 12 / 22 x 10	\$22.00	\$42.00
24 x 24 / 22 x 22	\$40.00	\$74.00
24 x 48 / 22 x 46	\$73.00	N/A

Door Return Grilles: Model 61DGD with Auxiliary Frame

- ▶ Inverted V-blades on 1/2" centers
- ▶ Made with heavy gauge, corrosion resistant steel
- ▶ Aluminum finish



Size (inches)	Net Each
12 x 12	\$57.00
16 x 16	\$75.00
18 x 12	\$64.00
18 x 18	\$83.00
24 x 12	\$71.00

Perforated Supply Diffusers

- 24x24 Insulated(R-4.2) Blankets - Neck to be field cut \$9.00 Each

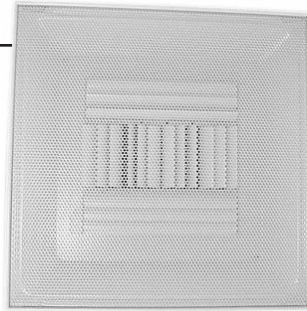

- Adjustable pattern controllers
- Removable face
- Corrosion-resistant steel construction
- Appliance white baked enamel finish
- Optional opposed blade damper
- 24x24 Lay-In frame or Surface mount frame
- Surface mounted diffusers includes plaster frame

Neck Size (inches)	Panel Size (inches)	CFM @ NC 30	Net Each (see pg. 9 for OBD pricing)
6	24 x 24	125	\$30.00
8	24 x 24	225	\$30.00
10	24 x 24	300	\$32.00
12	24 x 24	420	\$32.00
14	24 x 24	535	\$33.00
16	24 x 24	625	\$35.00

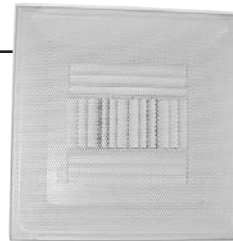

Perforated Supply Diffuser: Model 4320CB Lay-In

- Pattern controllers located in neck
- Blades are individually adjustable

Neck Size (inches)	Panel Size (inches)	CFM @ NC 30	Net Each (see pg. 9 for OBD pricing)
6	24 x 24	150	\$28.00
8	24 x 24	250	\$28.00
10	24 x 24	335	\$28.00
12	24 x 24	450	\$28.00
14	24 x 24	540	\$28.00
16	24 x 24	625	\$31.00

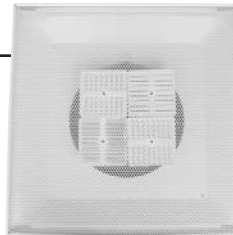

Perforated Supply Diffuser: Model 4320 Lay-In

- Pattern controllers located on inside of face

Neck Size (inches)	Panel Size (inches)	CFM @ NC 30	Net Each (see pg. 9 for OBD pricing)
6	12 x 12	115	\$38.00

All surface mounted diffusers will be furnished with plaster frame.

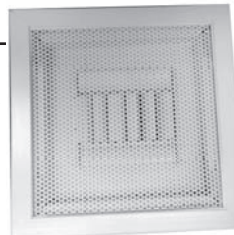

Perforated Supply Diffuser: Model 4320CB Surface Mount

- Pattern controllers located in neck
- Blades are individually adjustable

Neck Size (inches)	Panel Size (inches)	CFM @ NC 30	Net Each (see pg. 9 for OBD pricing)
6	12 x 12	150	\$37.00
8	12 x 12	250	\$37.00

All surface mounted diffusers will be furnished with plaster frame.

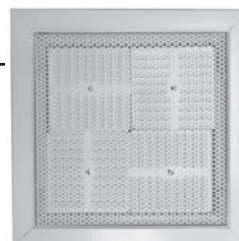

Perforated Supply Diffuser: Model 4320 Surface Mount

- Pattern controllers located on inside of face

- Matching perforated returns listed on page 10.

UNI DIFFUSERS & SQUARE CEILING SUPPLY DIFFUSERS



Ceiling Diffuser: Model UNI2



- Architectural plaque design
- 360° diffusion pattern
- Corrosion-resistant steel construction
- Appliance white baked enamel finish
- 24x24 or 12x12 lay-in frame
- Optional opposed blade damper - See page 9
- 24x24 Insulated Blankets (R-4.2) \$9.00 Each

Neck Size/ Panel Size (inches)	CFM @ NC 30	Net Each (see pg. 9 for OBD pricing)
6 / 12 x 12	215	\$41.00
8 / 12 x 12	375	\$41.00
6 / 24 x 24	245	\$38.00
8 / 24 x 24	360	\$38.00
10 / 24 x 24	555	\$38.00
12 / 24 x 24	720	\$38.00
14 / 24 x 24	955	\$38.00
15 / 24 x 24	1080	\$38.00

QB. Baffle available which converts the UNI to 1,2,3 way blow patterns. Net each \$10.00

Ceiling Diffuser: Model 6500L Lay-In



- Louvered face design
- High capacity with removable core
- Corrosion-resistant steel construction
- Appliance white baked enamel finish
- 24 x 24 Panel Size
- 12 x 12 Panel (6x6 & 9x9)
- 24x24 Insulated Blankets (R-4.2) \$9.00 Each

Neck Size (inches)	CFM @ NC 30	Net Each	Square to Round	Square OBD
6 x 6 / 6	180	\$36.00	\$8.00	\$10.00
6 x 6 / 12 x 12 panel	180	\$37.00	\$8.00	\$10.00
9 x 9 / 12 x 12 panel	375	\$42.00	\$10.00	\$12.00
9 x 9 / 9-8-6	375	\$40.00	\$10.00	\$12.00
12 x 12 / 12-10-8	630	\$49.00	\$11.00	\$13.00
15 x 15 / 14-12-10	935	\$60.00	\$12.00	\$23.00
18 x 18 / 16-14	1225	\$72.00	\$15.00	\$26.00
21 x 21 / 20-18-16	1630	\$94.00	\$20.00	\$29.00

For available round sizes, see above.
Square to round transitions shipped loose.
* See page 44 for additional transition sizes.

6500S Surface Mount Frame



Ceiling Opening =
Normal Duct size + 3"

- 24x24 Insulated Blankets (R-4.2) \$9.00Each

Neck Size (inches)	CFM @ NC 30	Net Each	Square to Round	Square OBD
6 x 6 / 6	180	\$25.00	\$8.00	\$10.00
9 x 9 / 9-8	375	\$27.00	\$10.00	\$12.00
12 x 12/12-10-8	630	\$37.00	\$11.00	\$13.00
15 x 15/14-12-10	935	\$47.00	\$12.00	\$22.00

For available round sizes, see above.
Square to round transitions shipped loose.
* See page 44 for additional transition sizes.

6500B Surface Mount with beveled drop face



Ceiling Opening =
Normal Duct size + 1"

- 24x24 Insulated Blankets - (R-4.2) \$9.00Each

Neck Size (inches)	CFM @ NC 30	Net Each	Square to Round	Square OBD
6 x 6 / 6	180	\$25.00	\$8.00	\$10.00
9 x 9 / 9-8	375	\$27.00	\$10.00	\$12.00
12 x 12/12-10-8	630	\$37.00	\$11.00	\$13.00
15 x 15/14-12-10	935	\$47.00	\$12.00	\$23.00
18 x 18/16-14	1225	\$60.00	\$15.00	\$26.00

For available round sizes, see above. Square to round transitions shipped loose.

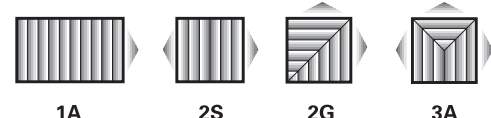

Square to rounds are available.
Blow patterns available at additional charge:



Neck Size (inches)	CFM @ NC 30	Net Each (see below for OBD pricing)
6	185	\$63.00
8	305	\$65.00
10	491	\$71.00
12	715	\$80.00
14	835	\$93.00
16	1140	\$115.00
18	1480	\$139.00

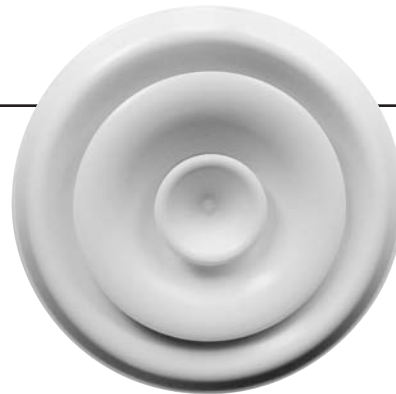

Round Ceiling Diffuser: Model RNR

- Two-position adjustable cones
- Removable inner cone assembly
- Corrosion-resistant steel construction
- Appliance white baked enamel finish

Neck Size (inches)	CFM @ NC 30	Net Each (see below for OBD pricing)	Insulated
6 / 12 x 12	215	\$26.00	NA
8 / 12 x 12	355	\$26.00	NA
6 / 24 x 24*	250	\$38.00	\$48.00
8 / 24 x 24*	380	\$38.00	\$48.00
10 / 24 x 24*	525	\$38.00	\$48.00
12 / 24 x 24*	735	\$38.00	\$48.00
14 / 24 x 24	975	\$38.00	NA



Square Ceiling Diffuser: Model RNS Lay-in

- Louvered panel face with round neck
- Removable inner cone
- Corrosion-resistant steel construction
- Appliance white baked enamel finish
- 3 cone pattern

*Available with Insulated Backs (R-4.2) Insulation

** 12 x 12 in 4 cone pattern

Radial Opposed Blade Damper: Model 4275

Neck Size (inches)	Net Each
6	\$17.00
8	\$18.00
10	\$20.00
12	\$24.00
14	\$27.00
16	\$31.00
18	\$74.00

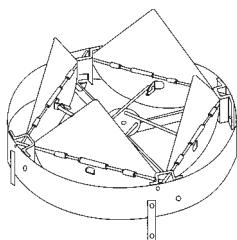

- Install on diffuser neck
- Adjustment from diffuser face
- Galvanized steel construction

Butterfly Damper: Model 4675

Neck Size (inches)	Net Each
6	\$10.00
8	\$13.00
10	\$15.00
12	\$17.00

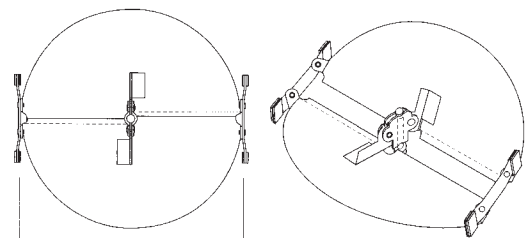

PERFORATED RETURN & EGGCRATE DIFFUSERS



Perforated Return Diffuser: Model 4360 Lay-In

- ▶ Removable face
- ▶ Corrosion-resistant steel construction
- ▶ Appliance white baked enamel finish
- ▶ DFA surface mount plaster frames available

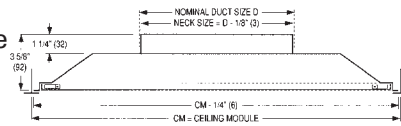
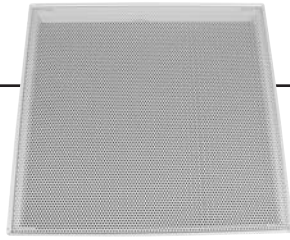

Neck Size (inches)	Panel Size (inches)	CFM @ NC 30	Net Each
6	24 x 24	205	\$28.00
8	24 x 24	349	\$28.00
10	24 x 24	460	\$28.00
12	24 x 24	650	\$28.00
14	24 x 24	855	\$28.00
16	24 x 24	1000	\$29.00
22 x 22	24 x 24	1900	\$26.00
22 x 46	24 x 48	3600	\$53.00
22 x 10	24 x 12	925	\$26.00

Perforated Return Panel: Model 4302

- ▶ Return panel only, for lay-in ceilings, no frame
- ▶ Appliance white baked enamel finish

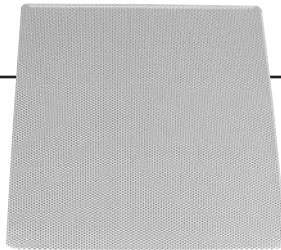

Neck Size (inches)	CFM @ NC 30	Net Each
24 x 12	900	\$14.00
24 x 24	1900	\$18.00
24 x 48	3500	\$27.00

Eggcrate Return Grilles: Model 61EC

- ▶ 1/2" x 1/2" x 1/2" aluminum eggcrate core
- ▶ Steel frame border
- ▶ Surface mount frame with countersunk screwholes
- ▶ Appliance white baked enamel finish

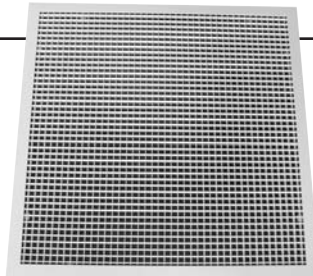

Neck Size (inches)	CFM @ NC 30	Net Each	With OBD
6 x 6	200	\$14.00	\$25.00
8 x 8	342	\$15.00	\$26.00
10 x 10	495	\$17.00	\$31.00
12 x 12	740	\$19.00	\$33.00
14 x 14	992	\$25.00	\$43.00
16 x 16	1200	\$29.00	N/A
18 x 18	1510	\$31.00	N/A
20 x 20	1875	\$35.00	N/A

Eggcrate Return Grilles: Model 61EC Lay-In

- ▶ Steel frame border
- ▶ 1/2" x 1/2" x 1/2" aluminum eggcrate core
- ▶ Appliance white baked enamel finish

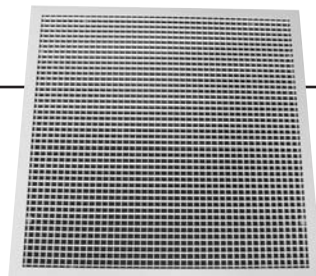

Neck Size (inches)	Panel Size (inches)	CFM @ NC 30	Net Each	With OBD
22 x 10	24 x 12	1285	\$21.00	\$39.00
22 x 22	24 x 24	2300	\$41.00	\$75.00
22 x 46	24 x 48	4400	\$96.00	N/A
22 x 22*	24 x 24	2300	\$44.00	\$80.00

*Core is removable for easy cleaning. Recommended for restaurants.

- ▶ White Plastic Eggcrate for lay-in T-bar ceiling.
- ▶ Straight blade 1/2" x 1/2" x 1/2".

Size (inches)	Net Each
24 x 24	\$25.00
24 x 48	\$30.00



Size (inches)	Net Each
12 x 12	\$16.00
16 x 16	\$17.00
20 x 20	\$22.00
24 x 12	\$22.00
24 x 24	\$23.00
48 x 24	\$49.00

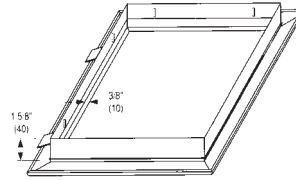

Plaster Frame: Model DFA

- ▶ Allows installation of lay-in diffuser or grille in hard ceiling
- ▶ Aluminum construction
- ▶ Appliance white baked enamel finish

Size	Net Each
2' x 2 Slots	\$16.00
4' x 1 Slot	\$16.00
4' x 1.5 Slots	\$19.00
4' x 2 Slots	\$19.00
4' x 3 Slots	\$24.00



Slot Diffuser Mounting Frame: Model PF

- ▶ Frame to be used in a sheetrock or plaster ceiling
- ▶ Plaster frames are made for 1" / 1.5" slots
- ▶ Allows installation of lay-in diffuser in hard ceiling
- ▶ Aluminum construction
- ▶ Appliance white baked enamel finish

Neck Size / Panel Size (inches)	CFM @ NC 30	Net Each
20 x 20 / 24 x 24	1566	\$64.00
44 x 20 / 48 x 24	3000	\$170.00

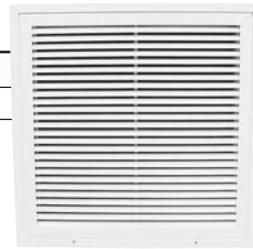
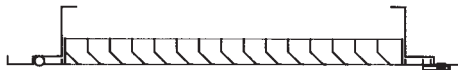

Lay-In Filter Grille: Model 61FBL45

- ▶ Louvered Face, Lay-in Filter Grille
- ▶ Corrosion-resistant steel construction
- ▶ Appliance white baked enamel finish

Neck Size / Panel Size (inches)	CFM @ NC 30	Net Each
20 x 20 / 24 x 24	1900	\$72.00

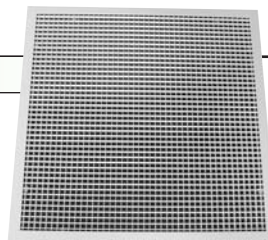

Eggcrate Lay-In Filter Grille: Model 61FEL

- ▶ Eggcrate, Lay-in Filter Grille
- ▶ 1/2" x 1/2" x 1/2" grid
- ▶ Appliance white baked enamel finish
- ▶ Core is removable for easy cleaning
- ▶ Recommended for restaurants
- ▶ Aluminum Core

Neck Size / Panel Size (inches)	CFM @ NC 30	Net Each
20 x 20 / 24 x 24	1827	\$56.00

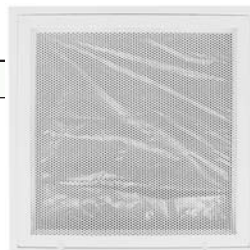

Perforated Lay-In Filter Grille: Model 61FPL

- ▶ Perforated Face, Lay-in Filter Grille
- ▶ Corrosion-resistant steel construction
- ▶ Appliance white baked enamel finish

All filter grilles accommodate a 1" filter (Supplied by others)

PLENUM & LINEAR SLOT DIFFUSERS



Plenum Slot Diffuser: Model 5710I - 5810I



- ▶ Adjustable vertical/horizontal pattern
- ▶ Insulated plenum
- ▶ 1" wide slots
- ▶ Lay-In frame

▶ For Surface Mount application see frames on page 11.

Model	Size/Slot	Neck Size	Unit Width	Unit Height	CFM@ NC30	Net Each
5710I	2'x 2 slots	6"round	4"	11"	115	\$48.00
5710I	2'x 2 slots	8"round	4"	11"	135	\$48.00
5710I	4'x 1 slots	8"round	2"	11"	150	\$59.00
5710I	4'x 2 slots	8"round	4"	11"	200	\$66.00
5710I	4'x 2 slots	10"oval	4"	11"	265	\$66.00
5710I	4'x 2 slots	12"oval	4"	11"	325	\$66.00
5710I	4'x 3 slots	12"oval	6"	11"	500	\$93.00
5715I	4'x 2 slots	10"oval	5"	11"	325	\$66.00
5810I*	2'x 2 slots	8"round	4"	11"	110	\$55.00
5810I*	4'x 2 slots	8"round	4"	11"	200	\$93.00
5810I*	4'x 2 slots	10"oval	4"	11"	220	\$93.00

*5810 have ice tong blades.

Linear Slot Ceiling Diffuser: Model Series 5000

- ▶ Lay-in or surface mount frame - **Specify when ordering**
- ▶ Extruded aluminum appliance white frame
- ▶ Steel black pattern controllers
- ▶ Type C - Concealed Mounting
- ▶ Unobtrusive architectural appearance
- ▶ 180° pattern controller adjustment
- ▶ Stocked in 4' or 6' length
- ▶ See below for specific slot model number

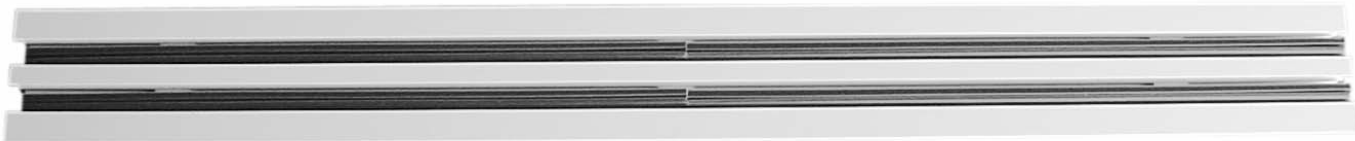

Slot Model	Slot Length	Slot Width	Number of Slots	Net Each	Plenum Model	Inlet	Add for Plenums
5075	4'	¾"	1	\$59.00	5375	8"	\$46.00
5075	4'	¾"	2	\$81.00	5375	8"or 10"	\$48.00
5010	4'	1"	2	\$81.00	5310	8"or 10"	\$48.00
5075	6'	¾"	2	\$108.00	N/A	N/A	N/A
5010	6'	1"	2	\$108.00	N/A	N/A	N/A
5075	6'	¾"	1	\$80.00	N/A	N/A	N/A

*Plenums for 6' slots need to be ordered from factory

- ▶ 6' diffusers are to be field cut for specified length (by others)
- ▶ All plenums have internal insulation. When ordering plenums, please specify neck size. 8" or 10"
- ▶ 8" inlet on plenum is round
- ▶ 10" inlet on plenum is round

IDCO Dampers

- ▶ Radial Sliding Blade
- ▶ Flexible Rotary Cable connects damper to a Phillips head screw operator mounted inside the plenum permitting air balance
- ▶ 6" - \$61.00
- ▶ 8" - \$61.00
- ▶ 10" - \$61.00
- ▶ 12" - \$61.00





Variable Geometry Thermo-Disc Ceiling Diffuser: Model VSD-4

The Rickard Model VSD-4 Variable Geometry Thermo-Disc Ceiling Diffuser is a thermally powered VAV diffuser which contains its own temperature sensing and volume control mechanism. The VSD-4 series will provide full VAV temperature control in both cooling and heating modes. The change-over between control modes is automatic and is carried out by means of a unique change-over mechanism. The change-over mechanism is operated by means of a thermal element identical to the one used for sensing room temperature. The Thermo-Disc is reliable and requires no routine preventative maintenance. All diffusers are lay-in models. Each diffuser can be surface mounted by using an auxiliary frame.

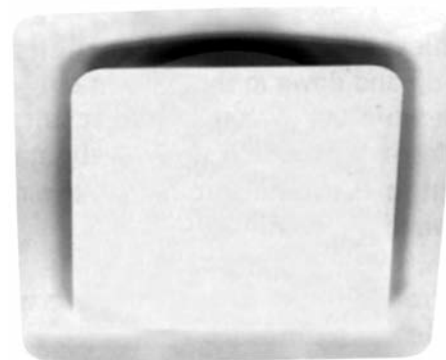

VAV, Fan Powered
Terminals

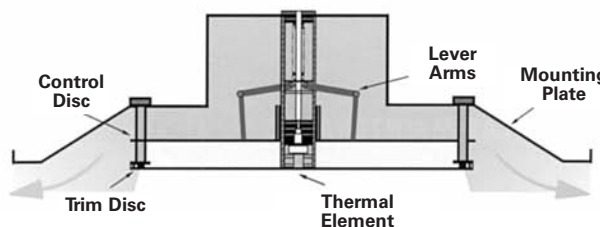
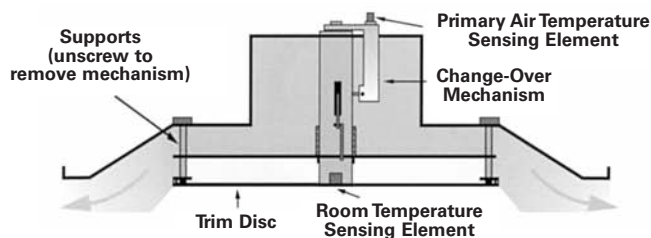

Neck Size (inches)	Reading	Neck Total Pressure (in w.g.)								
		0.08	0.12	0.16	0.20	0.24	0.28	0.32	0.36	0.40
6	Flow (c.f.m.)	85	104	119	133	146	159	169	180	189
	Throw (ft.)	4.9	6.9	8.9	9.8	10.8	11.5	12.1	13.1	13.8
	N.C. Level	-	-	-	-	26	28	31	33	35
8	Flow (c.f.m.)	203	250	290	324	358	390	413	438	462
	Throw (ft.)	6.6	8.5	9.8	10.5	11.8	12.8	13.8	14.8	15.4
	N.C. Level	-	27	28	29	30	33	36	38	40
10	Flow (c.f.m.)	297	362	419	468	513	553	591	627	663
	Throw (ft.)	7.9	8.5	10.5	11.5	12.8	13.8	14.8	15.4	16.7
	N.C. Level	-	27	29	31	33	36	38	40	42
12	Flow (c.f.m.)	373	452	530	593	650	703	752	798	843
	Throw (ft.)	8.2	9.2	10.8	12.1	13.8	15.1	15.7	17.1	17.7
	N.C. Level	27	27	30	32	35	37	39	41	43

Contact your local HMI office for pricing.



VAV Box: Model D3001 Single Duct Terminal Unit without Controls

- ▶ Heavy gauge steel housing
- ▶ Mechanically sealed and gasketed, leak resistant construction
- ▶ Meets requirements of NFPA 90A, NFPA 90B, and UL 181
- ▶ Multipoint inlet velocity sensor with center averaging
- ▶ Tight close-off damper. Leakage is less than 2% of nominal cfm at 3" wg as certified ARI 880
- ▶ Slip-and-drive discharge duct connection
- ▶ All units have fiber free liner
- ▶ All units with Control Enclosure
- ▶ All units with Access Door

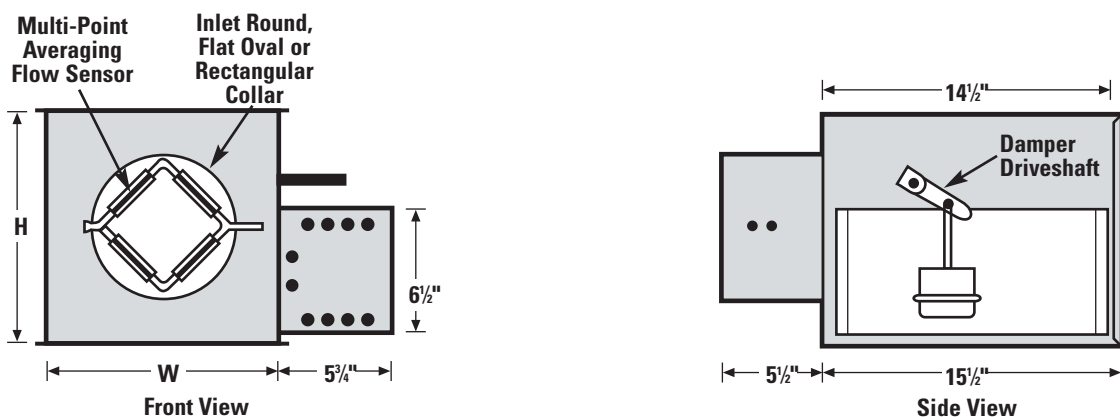

Dimensional Data

Imperial Units (inches)

Unit Size (inches)	Recommended CFM Range	Width (inches)	Height (inches)	Inlet (inches)	Model 3001 with No Controls	add for 2 Row Hot Water Coil	add for 1 Row Hot Water Coil
4	0-150	10	10	3 ⁷ / ₈ Round	\$137.00	\$82.00	\$63.00
5	0-250	10	10	4 ⁷ / ₈ Round	\$137.00	\$82.00	\$63.00
6	0-400	10	10	5 ⁷ / ₈ Round	\$137.00	\$82.00	\$63.00
8	0-700	12	12 ¹ / ₂	7 ⁷ / ₈ Round	\$161.00	\$88.00	\$68.00
10	0-1100	14	12 ¹ / ₂	9 ⁷ / ₈ Round	\$172.00	\$97.00	\$80.00
12	0-1600	18	12 ¹ / ₂	12 ¹⁵ / ₁₆ x 9 ¹³ / ₁₆ Oval	\$178.00	\$128.00	
14	0-2100	24	12 ¹ / ₂	16 ¹ / ₁₆ x 9 ¹³ / ₁₆ Oval	\$220.00	\$157.00	
16	0-2800	28	12 ¹ / ₂	19 ⁷ / ₁₆ x 9 ¹³ / ₁₆ Oval	\$231.00	\$163.00	
24 x 16	0-5350	38	18	23 ⁷ / ₈ x 15 ⁷ / ₈ Rectangular	\$293.00	\$249.00	

*Analog Electric Controls for VAV will need to be ordered from the factory.
Please contact your local Sales Office.

- * **Pneumatic VAV - Price D3001, Velocity Controller and Gold Pneumatic Operator.**
- * **Accessories furnished loose.**
- * **Tstat - by others**

Control Accessories	Net Each
Velocity Controller (DA/NO or RA/NC)	\$182
Johnson Pneumatic Operator 5-10 PSI (Black)	\$83
Kreuter Pneumatic Operator 5-10 PSI (Gold)	\$70
120/208/240 to 24v Transformer	\$25
277 to 24v Transformer	\$25



Hot Water Coils - 1 Row & 2 Row

- ½" O.D. copper tubes
- Aluminum sine-wave corrugation and rippled fins, 10 fins per inch
- 20 ga. galvanized steel casing
- Connection is slip and drive to ductwork
- AHRI Certified

Pricing on page 14

Dimensional Data - Hot Water Coils - 1 Row & 2 Row

Imperial Units (inches)

Unit Size	Width	Height
4	10	10
5	10	10
6	10	10
8	12	12½
10	14	12½
12	18	12½
14	24	12½
16	28	12½
24 x 16	38	18

Universal Fan Powered Terminal

Model D35NE and D35SE Fan Terminals with electric heat. These units are stocked with the KWs and voltages scheduled, however the KWs and voltages can be changed to accommodate most of your requirements. Check with our sales office.

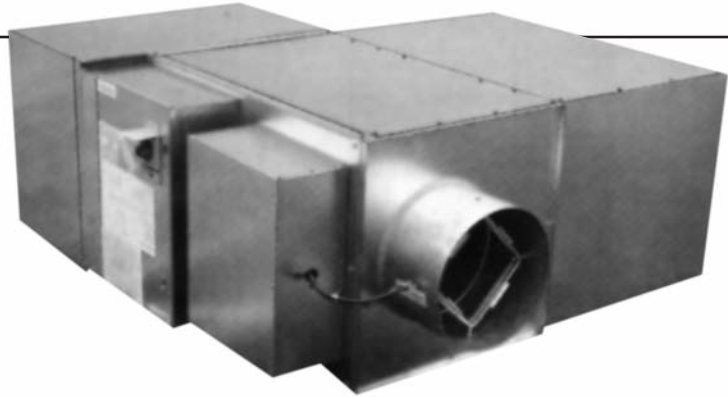

Accessories include:

- ▶ Intake filters
- ▶ Disconnect switch (Non-Fused)
- ▶ Inlet sensor (for DDC)
- ▶ Parallel units with PSC motors

Stock Fan Powered Terminal Units with Various Available Electric Heat Options

Model	Unit Size	Inlet Size	Primary CFM Range	Fan CFM Range @ .25	Elect. Char.	Available kW	Available Stages
35NE	2	8"Ø	140 - 750	200 - 625	277/1/60	0.8	1
35NE	2	8"Ø	140 - 750	200 - 625	277/1/60	1.6	1
35NE	2	8"Ø	140 - 750	200 - 625	277/1/60	3.3	1
35NE	2	8"Ø	140 - 750	200 - 625	277/1/60	2.5	1
35NE	2	8"Ø	140 - 750	200 - 625	277/1/60	5.0	1
35NE	2	8"Ø	140 - 750	200 - 625	480/3/60	5.0	2
35NE	2	8"Ø	140 - 750	200 - 625	480/3/60	5.0	3
35NE	3	10"Ø	220 - 1200	500 - 1120	277/1/60	0.8	1
35NE	3	10"Ø	220 - 1200	500 - 1120	277/1/60	1.5	1
35NE	3	10"Ø	220 - 1200	500 - 1120	277/1/60	2.5	1
35NE	3	10"Ø	220 - 1200	500 - 1120	277/1/60	3.3	1
35NE	3	10"Ø	220 - 1200	500 - 1120	277/1/60	5.0	1
35NE	3	10"Ø	220 - 1200	500 - 1120	277/1/60	5.8	1
35NE	3	10"Ø	220 - 1200	500 - 1120	277/1/60	6.6	1
35NE	3	10"Ø	220 - 1200	500 - 1120	480/3/60	5.0	2
35NE	3	10"Ø	220 - 1200	500 - 1120	480/3/60	5.0	3
35NE	3	10"Ø	220 - 1200	500 - 1120	480/3/60	10.0	2
35NE	3	10"Ø	220 - 1200	500 - 1120	480/3/60	10.0	3
35NE	5	12"Ø	300 - 1750	800 - 1525	277/1/60	1.7	1
35NE	5	12"Ø	300 - 1750	800 - 1525	277/1/60	3.3	1
35NE	5	12"Ø	300 - 1750	800 - 1525	277/1/60	3.6	1
35NE	5	12"Ø	300 - 1750	800 - 1525	277/1/60	5.0	1
35NE	5	12"Ø	300 - 1750	800 - 1525	277/1/60	10.0	2
35NE	5	12"Ø	300 - 1750	800 - 1525	480/3/60	5.0	3
35NE	5	12"Ø	300 - 1750	800 - 1525	480/3/60	10.0	2
35NE	5	12"Ø	300 - 1750	800 - 1525	480/3/60	10.0	3
35NE	5	12"Ø	300 - 1750	800 - 1525	480/3/60	15.0	2
35NE	5	12"Ø	300 - 1750	800 - 1525	480/3/60	15.0	3

Contact your local HMI office for pricing.

FAN POWERED TERMINAL UNITS



Model	Unit Size	Inlet Size	Primary CFM Range	Fan CFM @.25	Electric Charge	Available kW	Available Stages
35SE	3	10"Ø	175 - 750	175 - 750	277/1/60	.08	1
35SE	3	10"Ø	175 - 750	175 - 750	277/1/60	1.5	1
35SE	3	10"Ø	175 - 750	175 - 750	277/1/60	2.5	1
35SE	3	10"Ø	175 - 750	175 - 750	277/1/60	3.3	1
35SE	3	10"Ø	175 - 750	175 - 750	277/1/60	5.0	1
35SE	3	10"Ø	175 - 750	175 - 750	277/1/60	5.8	1
35SE	3	10"Ø	175 - 750	175 - 750	277/1/60	6.6	1
35SE	3	10"Ø	175 - 750	175 - 750	480/3/60	5.0	2
35SE	3	10"Ø	175 - 750	175 - 750	480/3/60	5.0	3
35SE	3	10"Ø	175 - 750	175 - 750	480/3/60	10.0	2
35SE	3	10"Ø	175 - 750	175 - 750	480/3/60	10.0	3

35SE	5	12"Ø	350 - 1750	350 - 1750	277/1/60	1.7	1
35SE	5	12"Ø	350 - 1750	350 - 1750	277/1/60	3.3	1
35SE	5	12"Ø	350 - 1750	350 - 1750	277/1/60	3.6	1
35SE	5	12"Ø	350 - 1750	350 - 1750	277/1/60	5.0	1
35SE	5	12"Ø	350 - 1750	350 - 1750	277/1/60	5.0	2
35SE	5	12"Ø	350 - 1750	350 - 1750	277/1/60	6.6	1
35SE	5	12"Ø	350 - 1750	350 - 1750	277/1/60	10.0	1
35SE	5	12"Ø	350 - 1750	350 - 1750	480/3/60	5.0	2
35SE	5	12"Ø	350 - 1750	350 - 1750	480/3/60	5.0	3
35SE	5	12"Ø	350 - 1750	350 - 1750	480/3/60	10.0	2
35SE	5	12"Ø	350 - 1750	350 - 1750	480/3/60	10.0	3
35SE	5	12"Ø	350 - 1750	350 - 1750	480/3/60	15.0	2
35SE	5	12"Ø	350 - 1750	350 - 1750	480/3/60	15.0	3

- CFM ranges are "suggested" only, units are NOT factory pre-set
- Model 35SE is Constant Volume Series Air Flow with ECM motor.
- Units include Intake Filter; Disconnect Switch; Inlet Sensor.
- Circuit Fusing (If Required) is NOT included.
- All units are ETL Listed and ARI Certified.
- Pneumatic Control (AVA) (Field mounted)

Contact your local HMI office for pricing.

ROUND CONTROL DAMPERS

- ▶ Exhaust or Fresh Air Damper
- ▶ 20 ga. galvanized steel Damper Shell - 8" deep
- ▶ 20 ga. galvanized steel Damper Blade
- ▶ 1/2" solid aluminum shaft
- ▶ Low leakage gasket
- ▶ Powered open, spring return closed

Size (inches)	Net Each
4	\$60.00
6	\$63.00
8	\$66.00
10	\$71.00
12	\$76.00
14	\$80.00
16	\$92.00

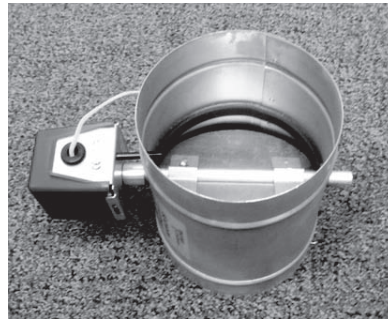

Control Damper Accessories	Net Each
24 volt Actuator	\$52.00
120 volt Actuator	\$69.00
Hand Quadrant	\$11.00
Shaft Extension	\$11.00

SMOKE DETECTORS



Smoke Detectors: Model D4120

System Sensor Duct smoke detectors are specifically designed for HVAC. System Sensor is the leader in the fire detection and fire safety devices. The unit provides sampling of air currents passing through a duct to detect a developing fire. Includes an 8" exhaust tube. Please specify length of sampling tube required.

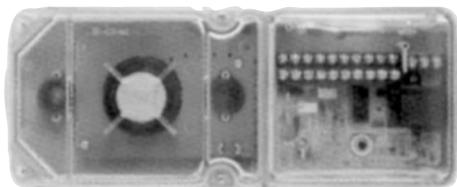

Model	Net Each
D4120 Smoke Detector	\$131.00
D4120W Watertight Unit	\$192.00
APA151-Piezo Annunciator	\$33.00
RTS151 Test Station w/Key	\$54.00
RTS 2 Multi-Signaling Test Station	\$85.00
AOS Add-on Strobe	\$44.00
3' Tube Only	\$10.00
5' Tube Only	\$13.00

- ▶ Price on Smoke Detector includes Sampling Tube 3' or 5'. Please indicate when placing order.
- ▶ Price listed above for tube is if tube purchased without detector

FIRE BARRIER DUCT WRAP & FIRE PILLOWS



3M Fire Barrier Duct Wrap for single and double wrapping in a variety of applications:

- Commercial Kitchen Grease Duct
- Air Ventilation and Chemical Exhaust Ducts
- Stair Pressurization Duct
- Hazardous Exhaust Ducts
- Trash and Linen Chutes

Key Benefits:

- Passes the rigors of internal grease duct fire tests UL 1978 and AC101
- Zero clearance to combustibles at overlap or collar for compact low profile that saves space in tight areas
- High flexibility for easy installation
- Foil encapsulated with unique center overlap seam for blanket strength, protection and less dust
- Safer fiber construction* for contractor peace of mind

*Has been demonstrated to be soluble in the lungs according to EU guidelines 67/548/EWG, Note Q for biopersistence.

Duct Wrap

Model	Size	Net Each
FB61524 P Wrap	1½" x24"x25'	\$229.00
*ACI21 Band/Seals	½" x 200'	\$43.00

*steel band

Fire Pillows

Model	Size	Net Each
3M-249	2" x 4" x 9"	\$19.00
3M-269	2" x 6" x 9"	\$22.00
3M-369	3" x 6" x 9"	\$25.00



3M Caulk and Silicone Caulk

Model	Color	Description	Net Each
3M CP25 WB+	Red	Flexible	\$13.00
3M 25WB	Blue	Intumescent	\$13.00
100 RTV Silicone	Clear	Silicone/Adhesive	\$13.00
Caulking Gun	N/A	N/A	\$7.00



ACCESS DOORS

Size (inches)	Net Each
6x6	\$16.00
8x8	\$19.00
10x10	\$20.00
12x12	\$23.00
14x14	\$26.00
16x16	\$30.00
18x18	\$34.00
20x20	\$38.00
24x24	\$47.00

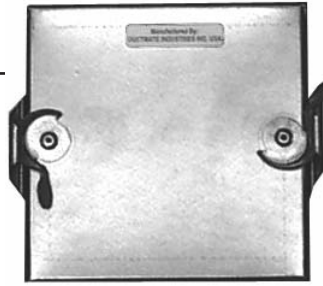

Access Doors: Model FDC

Ductmate Industries Model FD Cam, 1" Insulated with double gasket. Meets SMACNA requirements for low and medium pressure systems.

Round Size (inches)	Door Size	Net Each
5 & 6	8" x 4"	\$40.00
8	8" x 4"	\$40.00
10	12" x 8"	\$55.00
12 & 14	12" x 8"	\$55.00
16	16" x 12"	\$73.00
18	16" x 12"	\$73.00
20	16" x 12"	\$73.00
24	16" x 12"	\$81.00

Rectangular Sizes (inches)	Net Each	High Temp Up to 1000° Net Each
10x6	\$27.00	\$38.00
12x8	\$39.00	\$55.00
18x14	\$81.00	\$101.00
24x18	\$133.00	\$173.00

Access Doors: Model DR/DI

Ductmate Industries Insulated Access Doors For Round Duct, Flat Oval and Rectangular duct.



***2300°F doors are available from factory. UL grease doors are available from factory in stainless steel and black iron.

Size (inches)	Net Each
12x12	\$38.00
16x16	\$44.00
18x18	\$52.00
24x24	\$68.00

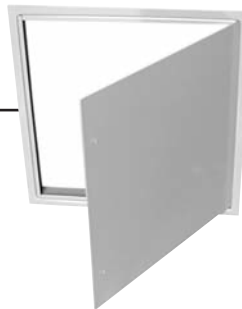

Access Doors: Model DSC-214M

Karp Model DSC Universal flush access door for walls and ceiling.

Non-Rated

Screwdriver operated lock

Finish is prime coat of rust inhibitive electrostatic powder, baked white enamel

Size (inches)	Net Each
12x12	\$143.00
14x14	\$154.00
16x16	\$165.00
24x24	\$201.00

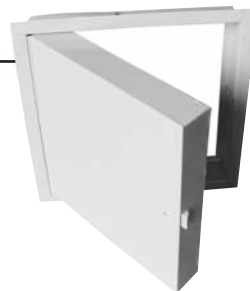

Fire Rated Access Doors: Model 150FR

Karp Model 150FR Fire Rated Access Door for walls and ceiling.

UL rated for wall: 1.5 hours.

Warnock Hershey rated for ceiling: 3 hours
2" thick fire rated insulation

Size (inches)	Net Each
12x12	\$106.00
16x16	\$131.00
24x24	\$167.00

Fire Rated Access Doors: Model 250FR

Karp Model 250FR for walls.

UL rated for wall only.

1.5 hour "B" Label in wall

Non-Insulated

FIRE & RADIATION DAMPERS

Model 0722		Model 0716	
Size (round)	Net Each	Size (square)	Net Each
6	\$26.00	6x6	\$25.00
8	\$27.00	8x8	\$26.00
10	\$28.00	10x10	\$31.00
12	\$33.00	12x12	\$39.00
14	\$35.00	22x22	\$71.00
16	\$39.00	22x10	\$40.00
		24x24	\$79.00

Ceiling Radiation Dampers

Nailor UL Classified Dampers, 22 gauge roll formed galvanized steel, standard frame depth.

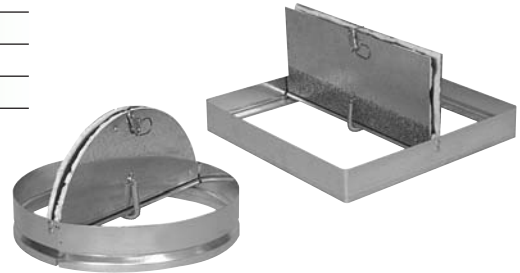

24x24 thermal blankets: \$14.00

Size (inches)	Net Each	Size (inches)	Net Each
6x6	\$55.00	18x8	\$63.00
8x6	\$55.00	18x10	\$68.00
8x8	\$55.00	18x12	\$69.00
10x6	\$55.00	18x14	\$74.00
10x8	\$57.00	18x16	\$77.00
10x10	\$58.00	18x18	\$77.00
12x6	\$55.00	20x6	\$64.00
12x8	\$57.00	20x8	\$64.00
12x10	\$58.00	20x10	\$63.00
12x12	\$59.00	20x12	\$70.00
14x6	\$59.00	20x14	\$74.00
14x8	\$59.00	20x16	\$74.00
14x10	\$63.00	20x18	\$81.00
14x12	\$64.00	20x20	\$81.00
14x14	\$66.00	24x12	\$74.00
16x6	\$59.00	24x14	\$81.00
16x8	\$59.00	24x16	\$81.00
16x10	\$63.00	24x18	\$88.00
16x12	\$64.00	24x20	\$88.00
16x14	\$69.00	24x24	\$94.00
16x16	\$69.00		

Dynamic Fire Dampers: Model D0114-12

Nailor Integral Sleeve Curtain Type
1 1/2 hour label - UL Approved
Vertical or Horizontal Mount
12" 22 gauge sleeve
Quick Set Retaining Angles



Replacement fusible links for
Radiation/Fire Dampers.



Melting Point:
165° \$6.00/ea.
212° \$6.00/ea.

Size (inches)	Net Each	Actual Dimensions (inches)
6 RD	\$72.00	8x8
8 RD	\$73.00	10x10
10 RD	\$80.00	12x12
12 RD	\$81.00	14x14
14 RD	\$94.00	16x16
16 RD	\$102.00	18x18
18 RD	\$111.00	20x20
20 RD	\$117.00	22x22



Dynamic Fire Dampers: Model D0134-12

Nailor Curtain Type
1 1/2 hour label - UL Approved
Vertical or Horizontal Mount
12" 22 gauge sleeve
Quick Set Retaining Angles
Rating - 2000 fpm @ 4" w.g.



Neoprene Isolators: Model RH

Model	Size	Rated Load	Rated Defl. (inches)	Net Each
RH	125A	125 lb.	0.04	\$12.00

Model RH Features:

- › Elastomer -in-shear noise Isolator
- › Static deflections up to 0.57" (15mm)
- › Load capacities up to 2000 lbs.
- › 500% overload fail-safe
- › 30 allowable rod misalignment bracket design



Hanging Spring Isolators: Model SH

Model	Size	Load	Defl	Outer Color	Free H.T.	O.D.	Net Each
SH	1-35	35	1.52	Blue	3.19	1.75	\$19.00
SH	1-70	70	1.36	Green	3.19	1.75	\$19.00
SH	1-125	125	1.23	Gray	3.19	1.75	\$19.00
SH	1-245	245	1.19	Brown	3.19	1.75	\$19.00
SH	1-370	370	0.96	Orange	3.19	1.75	\$19.00

Specifications: Model SH & SRH

- › Spring elements and brackets are powder coated
- › Load plates are bright zinc plated
- › Isolated hangers have a typical overload of 50%
- › Isolated hangers have a minimum Kx/Ky ratio of 1.0
- › Spring elements are safe at solid loading
- › Hanger brackets will carry (5) times overload without failure
- › Hanger brackets will allow 30° Rod Misalignment without short circuiting



Hanging Spring Isolators: Model SRH

Model	Size	Load	Defl	Outer Color	Free H.T.	O.D.	Net Each
SRH	1-35	35	1.61	Blue	3.19	1.75	\$25.00
SRH	1-70	70	1.55	Green	3.19	1.75	\$25.00
SRH	1-125	125	1.56	Gray	3.19	1.75	\$25.00
SRH	1-245	245	1.52	Brown	3.19	1.75	\$25.00
SRH	1-370	370	1.29	Orange	3.19	1.75	\$25.00



** Model RSP Waffle Pads - 2" x 2" x 3/4" - \$3.00 each **

** Full Sheet Price - (81 pads per sheet) - \$66.00**
 Full Sheet Measures 18" x 18" x 3/4"

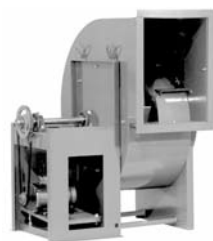

*Nonstock items
available on*

**LOREN
COOK
EXPRESS**

*Contact your
local HMI office.*



Fans, Curbs, Ventilators

Loren Cook Cross Reference - Fans/Ventilators

Loren Cook	Greenheck	Jenn/Breidert	Penn	Carnes	Twin City Fans
GC	SP	BF 100-950	Zephyr Jr	VCDB	T-Series
ACEB	GB	JEB/DB	Domex/KB/JB/MB/DXB	VEBK	BCRD/NBCR
ACED	G	JXD/RED	Domex/DX/SRV/Q/Q1/Q2	VEDK	CRRD/RCCX-D
PR	GRS/GRSF	GRV/RCX	Domex-DR	GS	GRV

GC Sizes 126 - 188 Gemini Ceiling Fan



Loren Cook Company certifies that the Gemini GC 126-188 are licensed to bear the AMCA Seal. The ratings shown are based on tests and procedures performed in accordance with AMCA Publication 211 and AMCA Publication 311, and comply with requirements of the AMCA Certified Ratings Program.



Type Gemini GC 126-188 are furnished standard with UL 507 & cUL 507 listing (Electric Fan/ GPWX).



Gemini GC 128 is a ENERGY STAR® certified product.

Specifications

- Description:** Fan shall be ceiling mounted, direct driven, centrifugal exhaust fan.
- Certifications:** Fan shall be manufactured by an ISO 9001 certified company. Fan shall be listed by Underwriters Laboratories (UL 507). Fan shall bear the AMCA Certified Ratings Seal for Sound and Air Performance. Select fans are ENERGY STAR® certified products.
- Construction:** Fan wheel housing and integral outlet duct collar shall be injection molded from a specially engineered resin exceeding UL requirements for smoke and heat generation. The outlet duct shall have provision for an aluminum backdraft damper with continuous aluminum hinge rod. The inlet box shall be minimum 22 gauge galvanized steel. Motor shall be isolation mounted to a one piece galvanized stamped steel integral motor mount/inlet. A field wiring compartment with disconnect receptacle shall be standard. To accommodate different ceiling thickness, an adjustable prepunched mounting bracket shall be provided. A white, non-yellowing, high impact styrene injection molded grille shall be provided as standard. Unit shall be designed with provision for field conversion from ceiling to inline. Unit shall be shipped in ISTA Certified Transit Tested Packaging.
- Wheel:** Wheel shall be centrifugal forward curved type, injection molded of polypropylene resin. Wheel shall be balanced in accordance with AMCA Standard 204-05, Balance Quality and Vibration Levels for Fans.
- Motor:** Motor shall be permanent split capacitor with permanently lubricated sealed bearings and include impedance or thermal overload protection and disconnect plug. Motor shall be furnished at 120v.
- Product:** Fan shall be model Gemini GC 126-188 as manufactured by Loren Cook Company of Springfield, Missouri.

Dimensions (inches)

Grille Material	A	B
Plastic	13-1/4	
Steel	13-1/2	15-1/2
Aluminum	13-3/4	

Weights (pounds)

Size	Shipping Weight
126 - 128	13
146 - 168	15
186 - 188	16

Weights are in pounds.

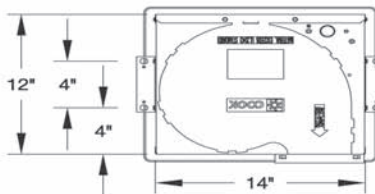

Ø5 15/16 O.D.

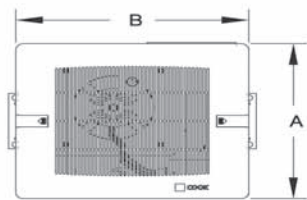
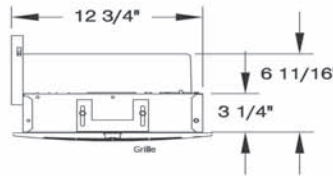
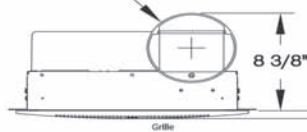

Inline kit listed on page 26

GC 126 - 188

Model	RPM	CFM/Watt at 0.1 SP	0.0 SP		.100 SP		.125 SP		.250 SP		.375 SP		.500 SP		.625 SP		.750 SP		.875 SP		1.000 SP		Net Each
			CFM	Sones	CFM	Sones	CFM	Sones	CFM	Sones	CFM	Sones	CFM	Sones	CFM	Sones	CFM	Sones	CFM	Sones	CFM	Sones	
★ GC-126	550	2.5	70	0.3	53	0.3	48	0.3	32	0.7													\$114
★ GC-128	750	2.8	94	0.8	82	0.9	79	0.9	63	1.0	49	1.3	37	2									
★ GC-146	900	2.9	114	1.2	105	1.2	103	1.2	90	1.3	77	1.5	64	2.0	50	2.5	36	3					
★ GC-148	1075	3.1	152	2.5	144	2.5	142	2.5	132	2.5	120	2.5	108	3.0	94	3.0	78	3.5	56	3.5			\$119
★ GC-166	1100	3.1	164	3.0	157	3.0	155	3.0	145	3.0	133	3.0	119	3.0	105	3.0	88	3.5	66	3.5	40	3.5	
GC-168	1160	3.0	180	3.5	173	3.5	171	3.5	162	3.5	150	3.5	136	4.0	121	4.0	105	4.5	86	4.5	54	5.0	
GC-186	1100	2.4	231	5.5	226	5.5	225	5.5	218	5.5	209	5.5	199	5.0	186	5.0	170	5.0	151	5.0	129	4.5	\$146
GC-188	1450	2.2	261	7.0	254	6.5	252	6.5	244	6.5	235	6.0	223	6.0	209	6.0	191	5.5	172	5.5	150	5.5	

★ ENERGY STAR® certified.

Performance certified is for Installation Type B: Free inlet, ducted outlet. Performance ratings for GC-126 through GC-188 include the effects of inlet grille. Speed (RPM) shown is nominal. Performance is based on actual speed of the test. The sound ratings shown are loudness values in spherical sones at 5 ft. (1.5m) in a spherical free field calculated per AMCA Standard 301. Values shown are for Installation Type B: Free inlet spherical sone levels.

GEMINI CEILING FANS

GC-422-862

LOREN COOK

GC Sizes 422 - 862 Gemini Ceiling Fan

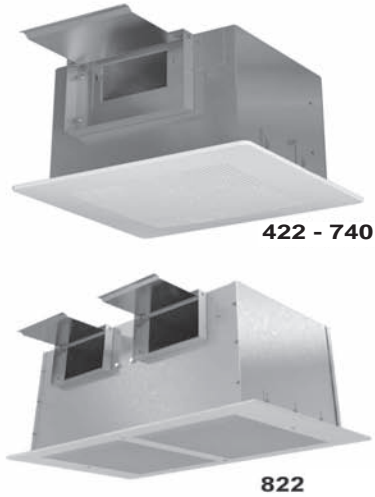

Loren Cook Company certifies that the Gemini GC 222-960 are licensed to bear the AMCA Seal. The ratings shown are based on tests and procedures performed in accordance with AMCA Publication 211 and AMCA Publication 311, and comply with requirements of the AMCA Certified Ratings Program.



Type Gemini GC 222-960 are furnished standard with UL 705 & cUL 705 listing (Power Ventilator/ ZACT).



Gemini GC 222-242 are ENERGY STAR® certified products.

Specifications

- Description:** Fan shall be ceiling, wall, or inline mounted, direct drive, centrifugal exhaust fan.
- Certifications:** Fan shall be manufactured by an ISO 9001 certified company. Fan shall be listed by Underwriters Laboratories (UL 705) and UL listed for Canada (cUL 705). Fan shall bear the AMCA Certified Ratings Seal for Sound and Air Performance.
- Construction:** Fan housing shall be minimum 20 gauge galvanized steel and acoustically insulated. Blower and motor assembly shall be mounted to a minimum 14 gauge reinforcing channel and shall be easily removable from the housing. Motor shall be mounted on vibration isolators. Unit shall be supplied with integral wiring box and disconnect receptacle shall be standard. Discharge position shall be convertible from right angle to straight through by moving interchangeable panels. The outlet duct collar shall include a reinforced aluminum damper with continuous aluminum hinge rod and nylon bushings. To accommodate different ceiling thickness, an adjustable prepunched mounting bracket shall be provided. A white, non-yellowing, high impact styrene injection molded grille shall be provided as standard on 200 and 300 series. A powder painted white steel grille shall be provided as standard on 400 - 900 series. Unit shall be shipped in ISTA Certified Transit Tested Packaging.
- Wheel:** Wheel shall be centrifugal forward curved type, constructed of galvanized steel. Wheel shall be balanced in accordance with AMCA Standard 204-05, Balance Quality and Vibration Levels for Fans.
- Motor:** Motor shall be permanent split capacitor with permanently lubricated sealed bearings, built-in thermal overload protection and disconnect plug. Motor shall be furnished at 120v.
- Product:** Fan shall be model Gemini GC 222-960 as manufactured by Loren Cook Company of Springfield, Missouri.

Dimensions (inches)

Size	Housing		Outlet		Grille						Shipping Weight
					Plastic		Steel		Deluxe Aluminum		
	L	W & H	A	B	J	K	J	K	J	K	
222 - 242	12-3/8	9-3/4	6	4-1/2	15-1/2	13-1/4	16-3/8	13-5/8	14-1/4	11	22
322 - 342	12-3/8	10-3/4	8	6	15-1/2	13-1/4	16-3/8	13-5/8	14-1/4	12-1/4	25
422	17	11-7/8	8	6	-	-	21	14-1/4	18-3/4	13-3/4	30
522 - 542	17	11-7/8	8	6	-	-	21	14-1/4	18-3/4	13-3/4	32
622 - 642	17	11-7/8	10-1/2	4-3/4	-	-	21	14-1/4	18-3/4	13-3/4	35
720 - 740	17	11-7/8	10-1/2	4-3/4	-	-	21	14-1/4	18-3/4	13-3/4	36
822 - 862	27	14-11/16	20	6	-	-	31-3/8	17-1/8	28-3/4	16-1/4	74
920 - 960	31	14-11/16	24-1/4	6	-	-	35-1/8	17-1/8	32-3/4	16-1/4	86

Weights are in pounds.

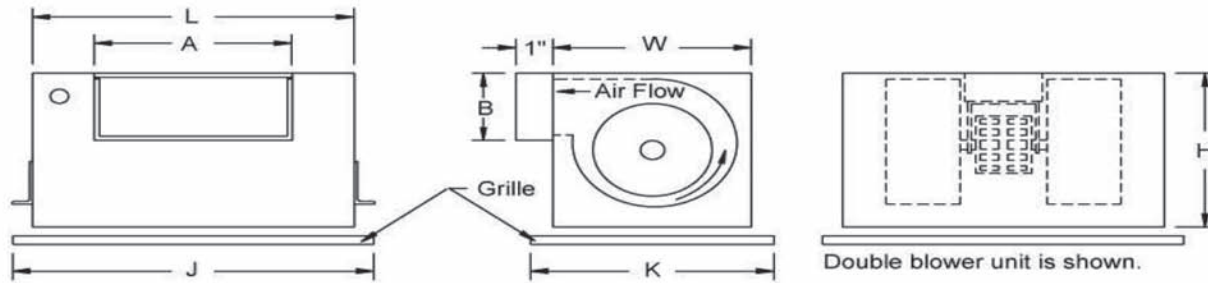

*Instructions to mount as inline fan can be provided as requested

GC 422 - 862

Model	RPM	CFM/Watt at 0.1 SP	0.0 SP		.100 SP		.125 SP		.250 SP		.375 SP		.500 SP		.625 SP		.750 SP		.875 SP		1.000 SP		Net Each
			CFM	Sones	CFM	Sones	CFM	Sones	CFM	Sones	CFM	Sones	CFM	Sones	CFM	Sones	CFM	Sones	CFM	Sones	CFM	Sones	
GC-422	1500	2.8	308	4.0	298	4.0	295	4.0	282	4.0	267	4.5	250	4.0	223	4.0							\$242
GC-522	1400	2.7	213	1.5	208	2.0	207	2.0	201	2.0	194	2.5											\$249
GC-542	1600	2.9	391	5.5	380	5.5	377	5.5	361	5.5	340	5.5	314	5.5	285	5.0	248	4.5					
GC-622	1400	3.3	501	3.5	486	3.5	482	3.5	461	3.0	433	3.0	392	3.0	339	3.0							
GC-642	1500	3.1	602	5.0	582	4.5	576	4.5	548	4.5	512	4.0	471	4.0	421	3.5	350	3.5					\$278
GC-720	1375	2.4	709	5.5	687	5.5	682	5.5	653	5.5	619	5.0	578	5.0	535	5.0	480	4.5	385	4.5			
GC-740	1625	2.2	852	7.0	823	7.0	815	7.0	775	6.5	727	6.0	672	6.0	616	5.0	552	4.5	463	4.0	303	3.5	\$389
GC-822	910	3.4	944	3.5	929	3.5	925	3.5	904	4.0	879	4.0	830	4.0									
GC-842	974	3.3	1187	5.0	1157	5.0	1149	5.0	1106	5.0	1043	4.5	905	4.5	637	3.5							\$571
GC-862	1098	3.4	1433	7.0	1371	7.0	1355	6.5	1266	6.5	1149	5.5	995	5.0	775	4.0							

Performance certified is for Installation Type B: Free inlet, ducted outlet. Performance ratings for GC-222 through GC-960 include the effects of inlet grille and backdraft damper. Speed (RPM) shown is nominal. Performance is based on actual speed of the test. The sound ratings shown are loudness values in spherical sones at 5 ft. (1.5m) in a spherical free field calculated per AMCA Standard 301. Values shown are for Installation Type B: Free inlet spherical sone levels.



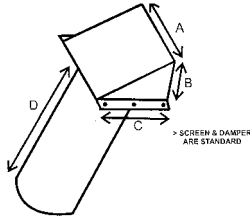

Jer-Air Aluminum Wall Caps

Model AWV	A	B	C	D
4"	5.25"	3.75"	6.5"	11.75"
6"	8.25"	5.25"	8.5"	7.75"
8"	11"	6.25"	11.75"	7.75"
10"	11"	6.25"	11.75"	7.75"
12"	13"	8.25"	13.75"	7.75"

Size (inches)	Net Each
4	\$24.00
6	\$27.00
8	\$36.00
10	\$40.00
12	\$62.00

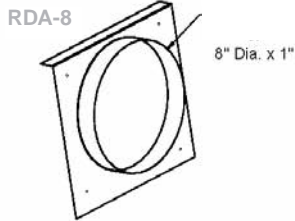

Model	Duct Diameter	Net Each
RDA-8	8	\$26.00

The Gemini 200-500 can be field converted from a rectangular outlet to a round outlet by removing the rectangular damper frame and replacing it with the RDA-8

Wall Cap - Broan 649

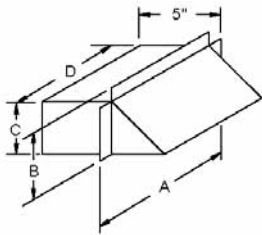

Gemini Series	Model	A	B	C	D	Net Each
	Alum.					
620-740	Broan 649	12 3/4	8 5/8	3 1/4	10	\$33.00

Eave Elbow

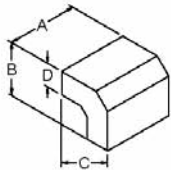

Gemini Series	Type	Model	A	B	C	D	Net Each
220-520	Long Eave	LE2	8 5/8	15 1/2	14	6 5/8	\$41.00
Broan	Short Eave	430	10	7 5/8	7 5/8	3 1/4	\$55.00

Roof Jack

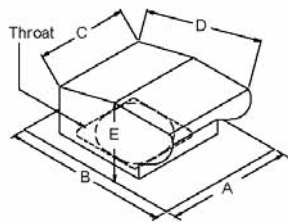

Gemini Series	Model	A	B Dia.	C	D	E	Throat Size	Net Each
122-184	RJR100	14 1/4	18 3/4	10 5/8	14 1/2	6 1/2	6 Dia.	\$45.00
220-520	RJ200	14 1/4	18 3/4	10 5/8	14 1/2	6 1/2	10 1/4 x 10 1/4	\$40.00
Broan	636	10 3/4	11	6 3/4	8 1/2	9 5/8	4	\$24.00
Broan	437	27 1/4	18 1/2	12 5/8	16 1/2	9 1/2	10 1/4 x 10 3/4	\$148.00

Miscellaneous Items

Item	Price Each
1) 5 Amp Speed Controller for GC126-862	\$36.00
2) 10 Amp Speed Controller	\$67.00
3) Vibration Isolator Kit for GC126-740	\$16.00
4) Heat/Cool Line Voltage T-Stat	\$30.00
5) Inline Adaptor for GC-126-186	\$36.00
6) Replacement Grilles for GC-126-186(Plastic)	\$28.00
7) Replacement Grilles for GC- 422-740	\$52.00
8) Replacement Grilles for GC- 822-862	\$73.00

Item	Price Each
9) 277v/120v transformers for GC126-186	\$171.00
10) 277v/120v transformers for GC422/542	\$247.00
11) 277v/120v transformers for GC622-862	\$360.00
12) Radiation damper for GC126-186 CRD-1	\$69.00
13) Radiation damper for GC422-740 CRD-4	\$85.00
14) Steel Grilles for GC126-186	\$31.00
15) GC Replacement Screws	\$3.00
16) GC Grille Screw Cover	\$3.00

Replacement Motors for GC fans - Call for pricing.



ACED CENTRIFUGAL EXHAUST VENTILATOR

LOREN COOK

Downblast Centrifugal Exhaust Ventilator Roof Mounted Direct Drive

Downblast centrifugal design with aluminum base. Includes two-piece top cap with stainless steel quick release latches, heavy-duty motor and cast iron drives. Motor, bearings and drives enclosed in weathertight compartment separated from air stream. Oil- and heat-resistant belts. built-in lifting lugs. 115V, 60Hz, 1 phase. AMCA certified; UL and CUL listed.



ACED Dimension Data

Size	A	B	C	G	T Sq.	Roof Opening Square*	Ship. Wt.
70	1-3/4	13-5/8	13-13/16	2	18	13-1/2	20
90	2-1/2	18-3/4	16-13/16	2	18	13-1/2	28
100	2-1/2	18-3/4	16-13/16	2	18	13-1/2	30
120	1-7/16	28-7/16	26-9/16	2	20	15-1/2	67
135	1-15/16	28-7/16	27-1/16	2	20	15-1/2	72

All dimensions in inches. *Roof opening size for curbs supplied by Loren Cook Company only. Weights in pounds.



Loren Cook Company certifies that the ACED shown herein is licensed to bear the AMCA Seal. The ratings shown are based on tests and procedures performed in accordance with AMCA Publication 211 and AMCA Publication 311 and comply with the requirements of the AMCA Certified Ratings Program.



Type ACED is furnished standard with UL 705 and cUL 705 listings (Power Ventilator/ZACT).

Sizes 70 - 100

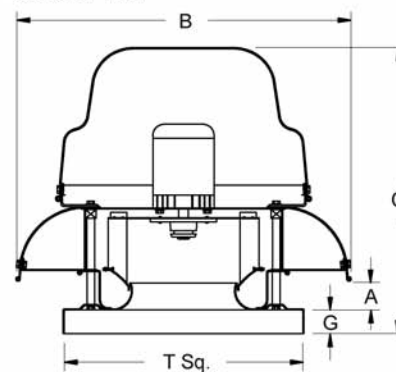

Sizes 120 - 180

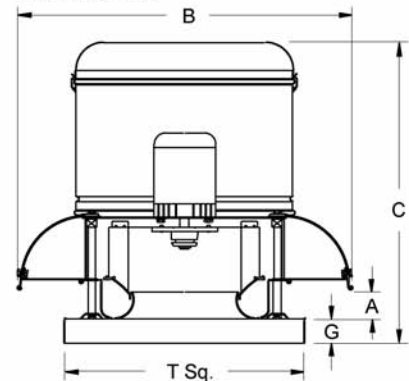

Catalog Number	Mtr. HP	Fan RPM	Tip Speed	Max. Watts	0.00" SP		0.125" SP		0.250" SP		0.375" SP		0.500" SP		0.625" SP		0.750" SP		Fan Price	Curb Price	Damper Price	Voltage
					Sone	BHP	Sone	BHP	Sone	BHP	Sone	BHP	Sone	BHP	Sone	BHP	Sone	BHP				
70C15DH	1/20	1550	2837	96	305		249		194		135								\$390	16 1/2 x 16 1/2	11 3/4 x 11 3/4	115/1
					5.2		5.2		5.1		5.0											
90C15DH	1/8	1550	3658	148	865		759		650		509		411		289		131		\$424	16 1/2 x 16 1/2	11 3/4 x 11 3/4	115/1
					9.1		9.1		8.9		8.4		8.0		7.6		7.2					
100C15DH	1/8	1550	4061	194	967		856		766		667		552		444		384		\$424	16 1/2 x 16 1/2	11 3/4 x 11 3/4	115/1
					11.0		11.0		10.8		10.7		10.5		10.4		10.2					
120C15D	1/4	1550	4869	-	1661		1596		1531		1463		1392		1324		1252		\$599	18 1/2 x 18 1/2	13 1/2 x 13 3/4	115/1
					12.4	.23	12.4	.23	12.4	.24	12.2	.25	12.0	.26	11.6	.27	11.3	.27				
135C15D	1/2	1550	5478	-	2364		2292		2219		2144		2066		1987		1910		\$660	18 1/2 x 18 1/2	13 3/4 x 13 3/4	115/1
					15.8	.41	15.8	.42	15.8	.43	15.7	.44	15.5	.46	15.3	.48	15.0	.48				

Price includes prewired disconnect and prewired speed controller.



Downblast Centrifugal Exhaust Ventilator Roof Mounted Belt Drive



Loren Cook Company certifies that the ACEB shown herein is licensed to bear the AMCA Seal. The ratings shown are based on tests and procedures performed in accordance with AMCA Publication 211 and AMCA Publication 311 and comply with the requirements of the AMCA Certified Ratings Program.



Type ACEB is furnished standard with UL 705 and cUL 705 listings (Power Ventilator/ZACT) when furnished with factory supplied motor.

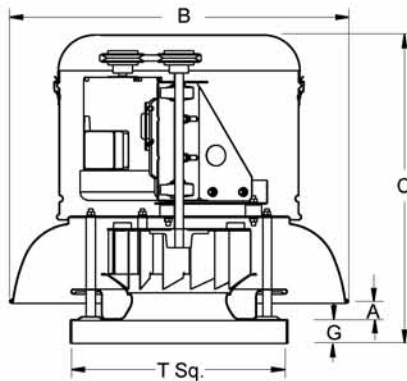

Description - Fan shall be a spun aluminum, roof mounted, belt driven, downblast centrifugal exhaust ventilator.

Certifications - Fan shall be manufactured at an ISO 9001 certified facility. Fan shall be listed by Underwriters Laboratories (UL 705) and UL listed for Canada (cUL 705). Fan shall bear the AMCA Certified Ratings Seal for Sound and Air Performance.

Construction - Fan shall be of bolted and welded construction utilizing corrosion resistant fasteners. The spun aluminum structural components shall be constructed of minimum 16 gauge marine alloy aluminum, bolted to a rigid aluminum support structure. The aluminum base shall have continuously welded curb cap corners for maximum leak protection. The discharge baffle shall have a rolled bead for added strength. A two piece top cap shall have stainless steel quick release latches to provide access into the motor compartment without the use of tools. An integral conduit chase shall be provided through the curb cap and into the motor compartment to facilitate wiring connections. The motor, bearings and drives shall be mounted on a minimum 14 gauge steel power assembly, isolated from the unit structure with rubber vibration isolators. These components shall be enclosed in a weather-tight compartment, separated from the exhaust airstream. Lifting lugs shall be provided to help prevent damage from improper lifting. Unit shall bear an engraved aluminum nameplate. Nameplate shall indicate design CFM, static pressure and maximum fan RPM. Unit shall be shipped in ISTA Certified Transit Tested Packaging.

Wheel - Wheel shall be centrifugal backward inclined, constructed of 100 percent aluminum, including a precision machined cast aluminum hub. Wheel inlet shall overlap an aerodynamic aluminum inlet cone to provide maximum performance and efficiency. Wheel shall be balanced in accordance with AMCA Standard 204-96, Balance Quality and Vibration Levels for Fans.

Motor - Motor shall be heavy duty type with permanently lubricated sealed ball bearings and furnished at the specified voltage, phase and enclosure.

Bearings - Bearings shall be designed and individually tested specifically for use in air handling applications. Construction shall be heavy duty regreasable ball type in a cast iron pillowblock housing selected for a minimum L50 life in excess of 200,000 hours at maximum cataloged operating speed.

Belts and Drives - Belts shall be oil and heat resistant, non-static type. Drives shall be precision machined cast iron type, keyed and securely attached to the wheel and motor shafts. Drives shall be sized for 150 percent of the installed motor horsepower. The variable pitch motor drive must be factory set to the specified fan RPM.

Product - Fan shall be model ACEB as manufactured by Loren Cook Company of Springfield, Missouri.

ACEB Dimension Data

Size	A	B	C	G	T Sq.	Roof Opening Square*	Ship. Wt.
60	2-7/8	23-9/16	21-1/8	2	18	13-1/2	30
70/80	2-7/8	23-9/16	21-1/8	2	18	13-1/2	30
100	2-7/8	23-9/16	21-1/8	2	18	13-1/2	30
120	1-13/16	28-7/16	26-7/8	2	20	15-1/2	55
150	3-1/16	32-7/8	28-7/8	2	24	19-1/2	70
165	3-9/16	32-7/8	29-3/8	2	24	19-1/2	75
180	3-15/16	37-11/16	34-1/2	3	30	25-1/2	90
245	6-1/8	47-5/8	39-7/8	3	30	25-1/2	240

Catalog Number	Mtr. HP/ Drv. Wt.	Fan RPM	Tip Speed	0.00" SP		0.125" SP		0.250" SP		0.375" SP		0.500" SP		0.625" SP		0.750" SP		Fan Price	Curb Price	Damper Price	Voltage
				Sone	BHP	Sone	BHP	Sone	BHP	Sone	BHP	Sone	BHP	Sone	BHP	Sone	BHP				
60C3B	1/4*	15 lbs.	1787	4678	259	243	226	209	190	169	143	\$626	16 1/2 x 16 1/2	\$68.00	11 3/4 x 11 3/4	\$43.00	115/1				
			1851	4845	268	253	237	220	202	182	160										
	1915	5013	278	263	247	231	214	196	175												
			13.9 .22	13.9 .22	13.8 .22	13.7 .22	13.6 .22	13.5 .22	13.3 .22												
	1981	5186	287	273	258	242	226	209	190												
			14.9 .25	14.8 .24	14.7 .24	14.7 .24	14.5 .24	14.4 .24	14.3 .24												
70C3B	1/4*	15 lbs.	1752	4585	384	358	333	306	275	245	215	\$634	16 1/2 x 16 1/2	\$68.00	11 3/4 x 11 3/4	\$43.00	115/1				
			1851	4751	397	372	348	323	294	264	237										
	1878	4916	411	387	363	340	313	283	256												
			15.1 .23	14.9 .22	14.6 .22	14.4 .22	14.1 .22	13.8 .22	13.5 .21												
	1941	5081	425	402	379	356	331	302	276												
			16.0 .25	15.8 .24	15.6 .24	15.4 .24	14.1 .22	14.9 .24	14.6 .23												
80C2B	1/6*	15 lbs.	740	1937	345	221						\$627	16 1/2 x 16 1/2	\$68.00	11 3/4 x 11 3/4	\$43.00	115/1				
			906	2371	422	327	102														
	1072	2806	3.4 .03	2.9 .03	2.3 .05																
			500	423	329																
	1238	3241	5.4 .05	4.9 .05	4.5 .05																
			577	510	434	356															
	1404	3675	7.6 .08	7.2 .08	6.8 .08	6.4 .08															
654			595	536	460	394															
1571	4112	9.2 .11	8.8 .11	8.5 .12	8.2 .12	7.6 .11															
			732	679	627	567	500	442	181												
			10.9 .16	10.5 .16	10.1 .16	9.8 .16	9.5 .16	9.0 .16	85 .12												
100C3B	1/4*	15 lbs.	1818	4759	1029	978	932	890	846	793	723	\$636	16 1/2 x 16 1/2	\$68.00	11 3/4 x 11 3/4	\$43.00	115/1				
			1884	4932	1066	1017	972	931	890	842	782										
	1950	5105	12.8 .17	12.8 .18	12.8 .18	12.6 .19	12.4 .19	12.2 .20	12.1 .20												
			1103	1056	1012	972	933	889	836												
	2014	5272	1140	1094	1051	1012	974	934	886												
			14.8 .21	14.8 .21	14.8 .22	14.6 .23	14.3 .23	14.1 .24	14.0 .24												
120C3B	1/4	15 lbs.	1411	4432	1512	1441	1368	1292	1216	1137	1021	\$700	18 1/2 x 18 1/2	\$79.00	13 3/4 x 13 3/4	\$47.00	115/1				
			10.8 .17	10.8 .18	10.8 .18	10.6 .20	10.2 .20	9.8 .20	9.5 .20												
	1618	1552	1484	1414	1342	1272	1193														
			11.9 .21	11.9 .21	11.9 .22	11.7 .23	11.5 .25	11.1 .25	10.8 .25												
150C4B	1/3	19 lbs.	1150	4516	2406	2298	2187	2069	1953	1835	1677	\$832	22 1/2 x 22 1/2	\$92.00	17 3/4 x 17 3/4	\$54.00	115/1				
					12.0 .26	12.0 .28	12.0 .30	11.8 .32	11.5 .33	11.1 .33	10.7 .33										
165C5B	1/2	23 lbs.	1063	4549	2933	2803	2669	2529	2389	2247	2064	\$877	22 1/2 x 22 1/2	\$92.00	17 3/4 x 17 3/4	\$54.00	115/1				
			12.2 .36	12.2 .36	12.1 .37	11.9 .40	11.6 .41	11.2 .41	10.9 .41												
	3136	3014	2891	2761	2628	2499	2362														
			1126	4863	14.0 .43	14.0 .44	14.0 .45	13.9 .47	13.5 .50	13.1 .51	12.8 .50										
180C7B	1	36 lbs.	1196	5636	4355	4240	4119	3993	3866	3736	3601	\$1238	28 1/2 x 28 1/2	\$118.00	23 3/4 x 23 3/4	\$68.00	460/3 *				
					18.5 .87	18.5 .89	18.5 .91	18.2 .94	17.8 .97	17.4 .99	16.7 1.00										
245C7B	1	36 lbs.	666	4271	6262	5996	5713	5380	4975	4464		\$1567	28 1/2 x 28 1/2	\$118.00	23 3/4 x 23 3/4	\$68.00	460/3 *				
			12.2 .81	12.2 .84	11.9 .86	11.3 10.5	10.5 .89	9.7 .89													
	6573	6320	6053	5751	5387	4954	4335														
			699	4463	13.3 .94	13.3 .97	13.1 .99	12.6 1.01	11.8 1.02	11.0 1.03	10.3 1.00										

Price includes prewired disconnect.

* Motor can be field converted to 208/3



Spun Aluminum Gravity Ventilator



Description - Unit shall be a spun aluminum, roof mounted gravity ventilator.

Construction - The unit shall be of bolted and welded construction utilizing corrosion resistant fasteners. The spun aluminum structural components shall be constructed of minimum 16 gauge marine alloy aluminum, bolted to a rigid aluminum support structure. The aluminum base shall have continuously welded curb cap corners for maximum leak protection. The spun aluminum baffle shall have a rolled bead for added strength. Birdscreen constructed of 1/2" mesh shall be mounted across the air opening. Unit shall bear an engraved aluminum nameplate. Nameplate shall indicate design CFM and static pressure. Unit shall be shipped in ISTA Certified Transit Tested Packaging.

Product - Unit shall be model PR as manufactured by Loren Cook Company of Springfield, Missouri.

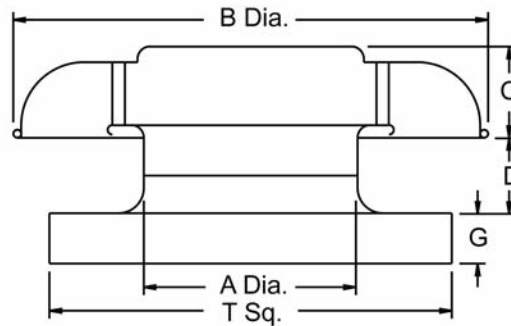

Size	A Dia.	B Dia.	C	D	G	T Sq.	Roof Opening	Approx. Ship Wt. - Lbs.	Net Each	Curb Price
8	8 1/2"	18 1/4"	4 5/8"	3 1/2"	2"	18"	13 1/2"	20	\$133	\$68-16.5x16.5
12	12 1/2"	28 1/4"	4 13/16"	3 1/2"	2"	20"	15 1/2"	30	\$157	\$79-18.5x18.5
16	16 1/2"	28 1/4"	5 1/8"	5 1/2"	2"	28"	23 1/2"	35	\$219	\$114 -26.5x26.5
20	20 1/2"	36 1/2"	6 3/4"	4 7/8"	2"	32"	27 1/2"	80	\$286	\$125 -30.5x30.5

► For curb dimensions, see page 32

PR - Intake Performance Data

Size	Throat Area (Sq. Ft.)	Face Area (Sq. Ft.)	CFM at 500 FPM Face Velocity	Pressure Drop (in WG)							
				0.05	0.1	0.125	0.15	0.2	0.25	0.3	0.375
				CFM							
8	.394	1.38	690	252	356	398	436	503	543	617	689
12	.852	2.04	1020	529	749	837	917	1059	1142	1297	1450
16	1.485	3.08	1540	936	1324	1480	1621	1872	2019	2293	2563
20	2.292	5.31	2655	1452	2054	2296	2516	2905	3132	3558	3977

PR - Relief Performance Data

Size	Throat Area (Sq. Ft.)	Face Area (Sq. Ft.)	Pressure Drop (in WG)								
			0.05	0.1	0.125	0.15	0.2	0.25	0.3	0.375	0.5
			CFM								
8	.394	1.38	212	299	334	366	423	473	518	579	669
12	.852	2.04	445	629	703	770	889	994	1089	1218	1406
16	1.485	3.08	786	1112	1243	1362	1573	1758	1926	2154	2487
20	2.292	5.31	1220	1726	1929	2114	2440	2729	2989	3342	3859



Roof Cap: Model 611

- ▶ For flat roof installation
- ▶ Aluminum - natural finish
- ▶ Built-in birdscreen
- ▶ For up to 8" round duct

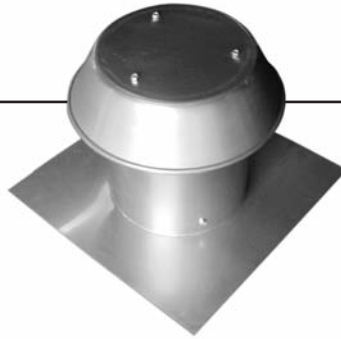

Net
Each

\$77.00

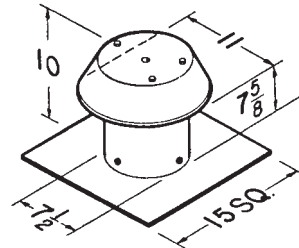

Roof Cap: Model 611CM

- ▶ For curb mount installation
- ▶ Other features same as Model 611

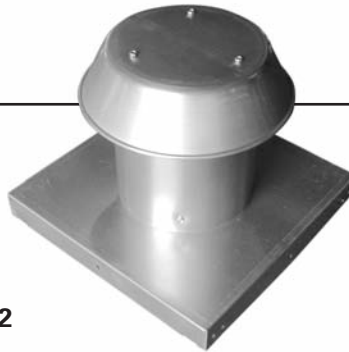

Curb -15x15
Price

\$62.00

Net
Each

\$100.00

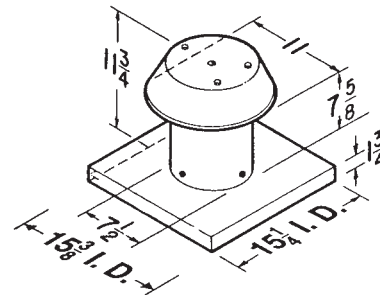

- ▶ For curb dimensions, see page 32

Roof Cap: Model 612

- ▶ For flat roof installation
- ▶ Aluminum - natural finish
- ▶ Built-in birdscreen
- ▶ For up to 12" round duct

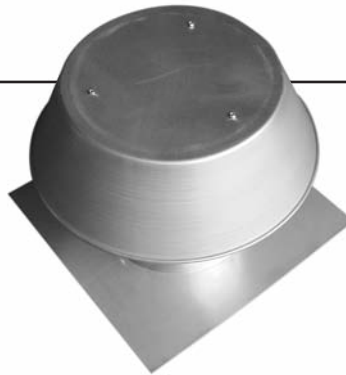

Net
Each

\$139.00

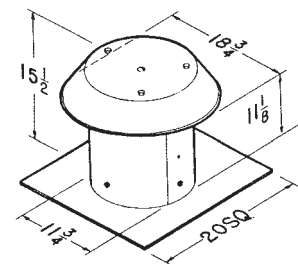

Roof Cap: Model 612CM

- ▶ For curb mount installation
- ▶ Other features same as Model 612

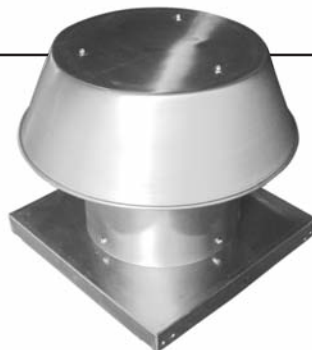

Curb -16.5x16.5
Price

\$68.00

Net
Each

\$149.00

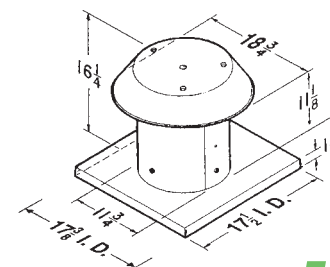

- ▶ For curb dimensions, see page 32

ROOF CURBS

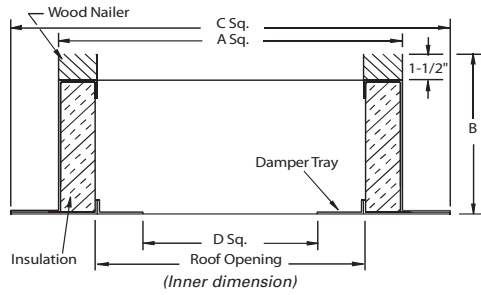

Self Flashing Roof Curbs

Roof curbs 12" & 13.5" high are constructed of 18 ga galvanized sheet metal with welded seams. They have a 1½" thick fiberglass insulation and factory installed treated wood nailer strip.

- 13.5" are for Loren Cook fans and gravity hoods

Curb Size OD A Sq	Height B	Damper Shelf D Sq	Net Each
12x12	12	N/A	\$53.00
15x15	12	9	\$62.00
16.5x16.5	13.5	9¾	\$68.00
18.5x18.5	13.5	11¾	\$79.00
22.5x22.5	13.5	15¾	\$92.00
26.5x26.5	13.5	19¾	\$114.00
28.5x28.5	13.5	21¾	\$118.00
30.5x30.5	13.5	23¾	\$125.00
33.75x33.75	12	27	\$148.00

C Sq = A Sq + 4"
Roof Opening = A Sq - 3"
(Inner dimension)

Size L x W x H (inches)	Net Each
36 x 4 x 12	\$92.00
48 x 4 x 12	\$116.00

Equipment Rails

- ▶ 18 Gauge Galvanized Steel Shell and Base Plate
- ▶ All welded unitize Construction
- ▶ Wood Nailer
- ▶ Flashing Cap - 18ga. galv. steel

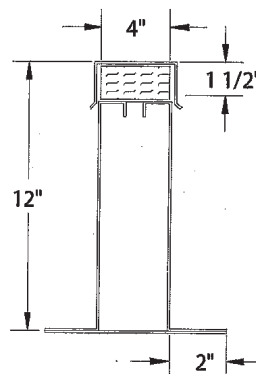

Size (inches)	Net Each
12 x 12	\$77.00
18 x 12	\$105.00
18 x 18	\$113.00
24 x 12	\$121.00
24 x 24	\$166.00
30 x 24	\$180.00
36 x 24	\$216.00
36 x 36	\$305.00
48 x 48	\$474.00

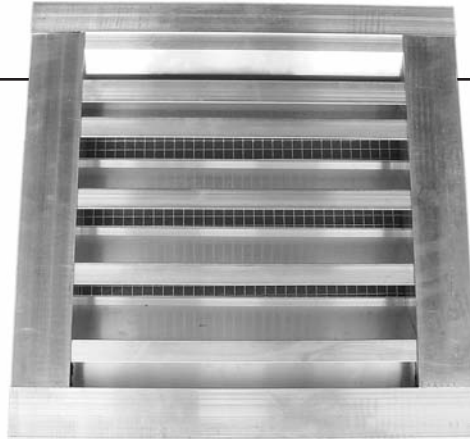

**Extruded Aluminum Louvers:
Nailor 1604DD**

- 4" Deep Dual Drainable Blades
- .080 Thick Blades
- 1½" Thick Frame
- Expanded Aluminum Bird Screen
- Mill Finish
- AMCA Certified 50% Free Area
- Removable Flanges for Channel Frame Application

Note: Flanges can be removed by removing screws and can be used in Channel Frame Application.

Model	Size (inches)	Net Each
1370CB	12x12	\$58.00
1370CB	18x18	\$86.00
1370CB	24x24	\$103.00
1370CB	36x36	\$156.00
1370CB	48x48	\$372.00

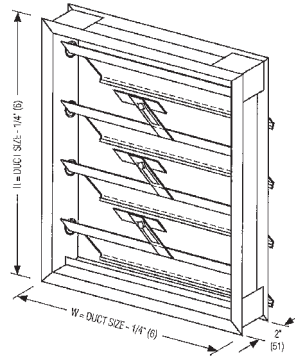

**Counterbalanced Backdraft Damper
Nailor 1370CB**

- Medium Duty
- Mill Finish
- 2" Deep frame, Mitered Corners
- Adjustable, plated steel weights mounted internally
- Blade Seals - Extruded PVC

Model	Deep	Order Size (inches)	Min. Open (W X H)	Net Each
168EX	4"	16½ x 7¾	16¾ x 8¼	\$79.00
808EX	4"	8½ x 7¾	8¾ x 8¼	\$61.00
168FL	1½"	16½ x 7¾	17 x 8	\$77.00
125FL	1½"	12 x 4¾	12½ x 5	\$60.00



**Extruded Aluminum Brick Vents:
Model EX and FL**

- 1½" or 4" Deep
- Includes Water Stop and Insect Screen
- Aluminum Construction
- Clear anodized

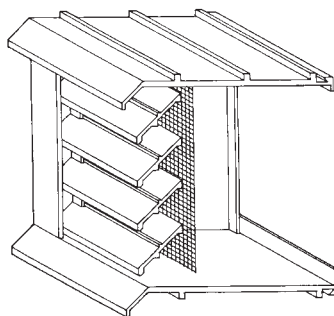

Model EX

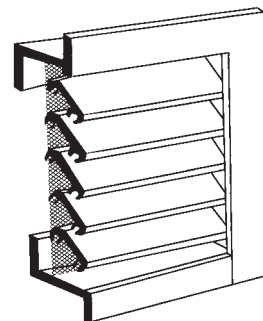

Model FL

Note: Model Ex 4" Deep No Flange
Model FL 1½" Deep With Flange



PIPE FLASHING SYSTEMS

The solution of weathertight penetration seals

RPS Pipe Portal® Flashing Systems are a versatile, leakproof, and weathertight solution to routing pipes through a roof. The RPS Pipe Portal® Flashing Systems is designed to allow for both vertical and horizontal pipe movement, yet provide a maintenance-free permanent installation which accommodates round pipe sizes of 3/8" up to 6". The key to the effectiveness of the Pipe Portal® System is the cover and the cap. The seamless cover is molded of UV-resistant ABS plastic which has factory laminated acrylic coating to give high resistance to deterioration from both ozone and ultraviolet rays of the sun, as well as a serviceable temperature range of -40° F to 160° F. Integral to the cover is a molded collar with sealing ring which mechanically locks the flexible cap to the cover creating a Weather-Tite Pressure Seal. The flexible rubber caps are molded of time-proven EPDM rubber which is resistant to deterioration from both ozone and ultraviolet rays of the sun with a serviceable temperature range of -60° F to +250° F. The conically-shaped steps of the nipple(s) provides a taut waterproof seal around the pipe(s) and the furnished stainless steel clamp(s) give added protection to guarantee the pipe seal(s).

- **RPS CURB...** The sure way of attaching roof flashing... insulated sidewalls to prevent condensation.
- **MOLDED ABS COVER...** UV and ozone resistant...crowned to shed water... reinforcing ribs to counteract snow loads... integral counterflashing with drip edge to direct water away from flashings.
- **MOLDED EPDM RUBBER CAP...** Precision molded to fit actual pipe sizes...integral mechanical lock to cover with Weather-Tite Pressure Seal...allows flexibility in any direction while maintaining pipe seal.
- **STAINLESS STEEL CLAMP(S)...** Provides additional assurance of effective pipe seal at cap.

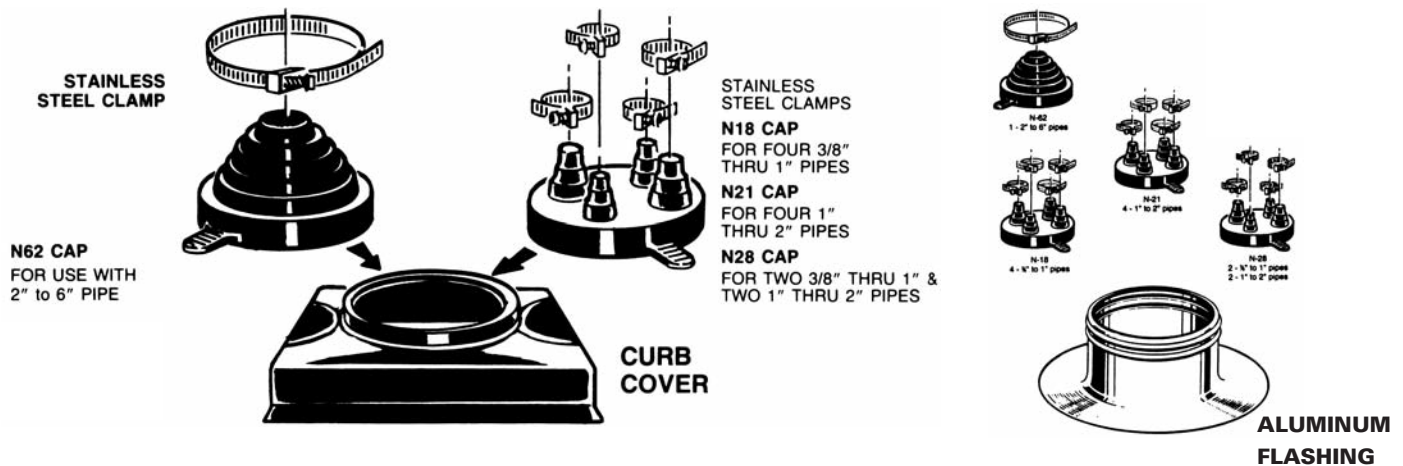

MODEL	DESCRIPTION	NET EACH
ABS Curb Cap	1 hole cover for 12 x 12 curb	\$69.00
N18 Cap/Clamps	For four 3/8" to 1" pipes	\$44.00
N21 Cap/Clamps	For four 1" to 2" pipes	\$44.00
N28 Cap/Clamps	For two 3/8" to 1" & two 1" to 2" pipes	\$44.00
N62 Cap/Clamps	For one 2" to 6" pipe	\$44.00
Alum. - Short	Aluminum Flashing 4"	\$52.00
Alum. - Tall	Aluminum Flashing 13"	\$145.00

****For 12 x 12 curb, see page 32****



PIPE FLASHING SYSTEMS

The solution of weathertight penetration seals

RPS Deck-Mate Flashing Systems are designed to accommodate pipes from 4" to 13" in diameter and work in conjunction with any configuration of colligated metal roofing or wall systems. The flexibility of the EPDM rubberflashing allows for both vertical and horizontal pipe movement, yet provides a maintenance-free permanent installation. To form a positive seal with the metal roofing or siding, the Deck-Mate is engineered and manufactured with a flexible aluminum base which can easily be conformed to any contour or irregularity in the underlying metal panels. To prevent any possible corrosive effects with the aluminum flange, the rubber boot is fully molded under the aluminum providing a barrier between the aluminum flange and any dis-similar metals. In addition the rubber under the aluminum flange gives assurance of an added seal between the Deck-Mate and the panel. Field attachment of the Deck-Mate to the panel is simple with silicone sealant and standard sheet metal fasteners with rubber washers.

- **ALUMINUM FLANGE...** Seamless construction with no leaks...engineered directly to the rubber boot during the molding process... factory adhered flange can't be lost.
- **MOLDED EPDM RUBBER BOOT...** Precision molded to fit actual pipe sizes...allows flexibility in any direction while maintaining pipe seal.
- **STAINLESS STEEL CLAMP...** Provides additional assurance of effective pipe seal at cap.

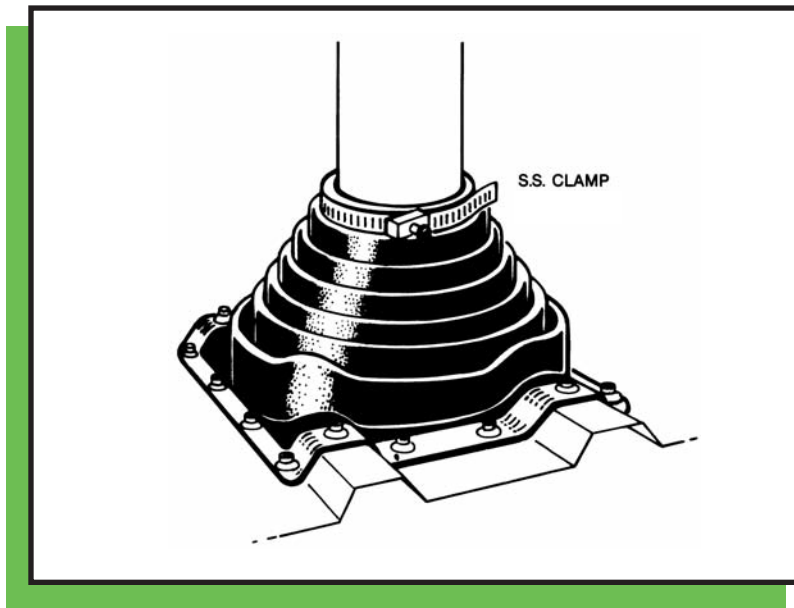

Serviceable Temperature Range:

DM (EPDM)

-60°F to +270°F

SDM (Silicone)

-100°F to +500°F

MODEL	DESCRIPTION	NET EACH
DM5	Flashing 4" to 7"	\$52.00
DM8	Flashing 7" to 13"	\$100.00
SDM5	High temp flashing 4" to 7"	\$121.00
SDM8	High temp flashing 7" to 13"	\$260.00
Clear Caulk	100 RTV Silicone	\$7.00



- Single-Wall Spiral
- Medium Pressure Galvanized Paintable Steel G-60
- Construction with Gasketed Connections

SPIRAL DUCT

Dia.	Length	Net Each	Weight
4"	10' Ft	\$25.00	10.23
6"	10' Ft	\$33.00	15.89
8"	10' Ft	\$38.00	21.46
10"	10' Ft	\$48.00	27.00
12"	10' Ft	\$56.00	32.50
14"	10' Ft	\$70.00	38.00
16"	10' Ft	\$96.00	43.48
18"	10' Ft	\$105.00	48.96
20"	10' Ft	\$117.00	54.43
24"	10' Ft	\$140.00	65.38

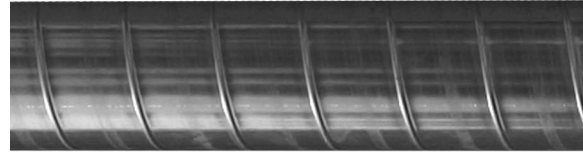

- Positive (0" - 10" wg)
- Negative (-2" wg)

REDUCERS

Dia. A	Dia. B	Net Each	Dia. A	Dia. B	Net Each
6"	4"	\$22.00	16"	12"	\$40.00
8"	6"	\$22.00	16"	14"	\$40.00
10"	6"	\$25.00	18"	14"	\$62.00
10"	8"	\$25.00	18"	16"	\$62.00
12"	8"	\$28.00	20"	16"	\$69.00
12"	10"	\$28.00	20"	18"	\$69.00
14"	10"	\$31.00	24"	20"	\$95.00
14"	12"	\$31.00			



SADDLE TAP

Dia. B Main	Dia. A Main	Net Each	Dia. B Main	Dia. A Main	Net Each
6"	4"	\$19.00	16"	14"	\$33.00
6"	6"	\$20.00	18 - 20"	10"	\$23.00
8"	6"	\$20.00	18 - 20"	12"	\$28.00
8"	8"	\$21.00	18"	8"	\$22.00
10"	6"	\$19.00	18"	14"	\$51.00
10"	8"	\$21.00	18"	16"	\$51.00
10"	10"	\$23.00	18"	18"	\$67.00
12"	8"	\$21.00	20"	14"	\$51.00
12"	10"	\$23.00	20"	20"	\$73.00
12"	12"	\$29.00	24"	10"	\$22.00
14 - 16"	10"	\$23.00	24"	12"	\$29.00
14 - 16"	12"	\$29.00	24"	14"	\$30.00
14 - 16"	16"	\$37.00	24"	16"	\$37.00
14"	6"	\$20.00	24"	18"	\$49.00
14"	8"	\$21.00	24"	20"	\$55.00
14"	14"	\$3000			



90° ELBOW

Dia.	Net Each
4"	\$20.00
6"	\$22.00
8"	\$32.00
10"	\$45.00
12"	\$60.00
14"	\$83.00
16"	\$106.00
18"	\$137.00
20"	\$164.00
24"	\$228.00



14" - 24"
5 piece Construction



4" - 12"
1 piece Construction

45° ELBOW

Dia.	Net Each
4"	\$17.00
6"	\$19.00
8"	\$22.00
10"	\$29.00
12"	\$37.00
14"	\$52.00
16"	\$64.00
18"	\$75.00
20"	\$86.00
24"	\$118.00



14" - 24"
3 piece Construction



4" - 12"
1 piece Construction

VOLUME DAMPERS

Dia.	Net Each
4"	\$30.00
6"	\$35.00
8"	\$38.00
10"	\$45.00
12"	\$52.00
14"	\$68.00
16"	\$76.00
18"	\$84.00
20"	\$93.00
24"	\$114.00



Volume Damper

COUPLING

Dia.	Net Each
4"	\$9.00
6"	\$9.00
8"	\$10.00
10"	\$11.00
12"	\$14.00
14"	\$18.00
16"	\$19.00
18"	\$20.00
20"	\$23.00
24"	\$30.00



PLUG

Dia.	Net Each
4"	\$11.00
6"	\$12.00
8"	\$14.00
10"	\$17.00
12"	\$18.00
14"	\$21.00
16"	\$25.00
18"	\$31.00
20"	\$39.00
24"	\$50.00



BELL MOUTH

Dia.	Net Each
4"	\$15.00
6"	\$15.00
8"	\$15.00
10"	\$17.00
12"	\$18.00
14"	\$19.00
16"	\$20.00
18"	\$21.00
20"	\$22.00
24"	\$24.00



UNIVERSAL SPIRAL DUCT GRILL

Size	Minimum Duct Diameter (inches)	CFM • NC 30	Net Each
17 x 3	6	190	\$59.00
21 x 3	6	225	\$63.00
25 x 3	6	275	\$72.00
17 x 6	12	315	\$72.00
21 x 6	12	370	\$81.00
25 x 6	12	440	\$96.00

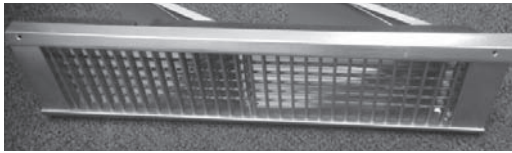

GRIPPLE

LOOPS, STUDS & EYELETS

Provides lighter, easier and faster alternative to threaded rod for hanging mechanical and electrical and HVAC equipment. Ready to use; requires no additional preparation time. Includes cable with loop or stud end fixing; grip secures free of cable and allows height adjustment of hanging object.

- Loop** For wrap-around anchoring on bar joists or other roof structures.
- Stud** For anchoring into concrete or metal. Includes ¼ drop-in expansion anchor.
- Eyelet** For anchoring into concrete, ceiling or decking.



Model	Weight	Length	End Fixing	Price per bag of 10
HF-0210L	100	10'	Loop	\$75
HF-0215L	100	15'	Loop	\$81
HF-0310L	200	10'	Loop	\$84
HF-0315L	200	15'	Loop	\$99
HF-0310S	200	10'	Stud	\$86
HF-0315S	200	15'	Stud	\$92
HF-EYE90G	100	10'	Eye	\$72
HF-EYE90G	100	15'	Eye	\$84
HFWR	cable and wire cutter			\$49
HF-CCS	corner saddle for rectangular duct work			\$0.50 Each



FLEXIBLE DUCT: R-VALUE 6.0



Construction

Air Tight Inner Core - Double lamination of strong polyester encapsulates a steel wire helix.
 Insulation - Formaldehyde-free Multi-thicknesses (R6) wraps the double layer inner core.
 Jacket- Tough and durable bi-directional fiber reinforced metalized polyester jacket.



Application and Compliances

Product is designed for indoor use as a supply or return air duct in low to medium pressure residential and commercial heating and air conditioning systems. R values 6.0 can be used to complete air duct systems, branch duct, connecting to mixing boxes, diffusers, room inlets, or other devices. R factor requirements are determined by geographic building codes.

Performance Data

Conforms to U.L. Standard 181.

Intertek Testing Service

Max. Rated Velocity	5500FPM
Max. Rated Positive Pressure	10in. W.G.
Max. Rated Negative Pressure	3/4in. W.G.

See installation instructions for joint treatments

Flame Spread 25 Max.

Smoke Developed 50 Max

Code Compliance: NFPA 90A and 90B, UL181

Size (inches)	Box (25') COST
4	\$22.00
5	\$25.00
6	\$28.00
7	\$31.00
8	\$33.00
9	\$38.00
10	\$42.00
12	\$52.00
14	\$62.00
16	\$72.00
18	\$84.00
20	\$102.00
	Net Each
36" Panduit Straps 50/pack	\$13.00
48" Panduit Straps 50/pack	\$17.00
Panduit Gun	\$54.00
Panduit Gun w/Auto Cut Off	\$70.00

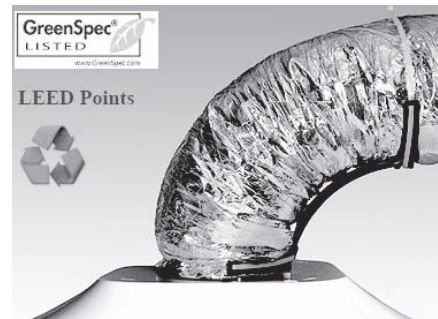

Flexright Duct Brace \$6.00

UNINSULATED FLEXIBLE DUCT



Size (inches)	Box (25') COST
4	\$17.00
5	\$20.00
6	\$22.00
7	\$26.00
8	\$28.00
9	\$32.00
10	\$39.00
12	\$45.00
14	\$58.00
16	\$68.00
18	\$84.00

Uninsulated Flexible Duct: Model UPC #050

An uninsulated, U.L. 181, Class 1 Air Connector, constructed of a triple lamination of metalized polyester, aluminum foil and polyester film encapsulating a steel wire helix.

Performance Data:

Rated Positive Pressure: 10" w.g. per U.L. 181

Recommended Operating Pressure: 6" w.g. pos., all dia.; 3/4" neg., all dia.

Velocity: 5,000 FPM

Standard Diameters: 3"-20"

Flame Spread/Smoke Developed:

Less than 25/Less than 50.

DUCT TAPE



Nashua / PolyKen / Berry Plastics

Contractor Grade/Printed Metalized Polycoated

Printed smooth flow metalized polyethylene for use on flex duct, sheet metal and fiberboard. More flexible and conformable with higher adhesive values than most rigid foil products.

Model	Size (inches)	Description	Net Each	Rolls per case
Polyken 557	2	Silver UL 181B-FX for flexible air duct & air connectors	\$16.00	24
Polyken 557	2½	Silver UL 181B-FX for flexible air duct & air connectors	\$19.00	16
Polyken 557	3	Silver UL 181B-FX for flexible air duct & air connectors	\$21.00	16
Polyken 339	2½	Aluminum UL 181B-A-P UL 181B-FX Peel-Off	\$19.00	16
Nashua FSK	3	Foil/Skrim/Kraft FSK Duct Board & Insulation	\$16.00	16
360-17 ALU	3	Mastic Tape Temp Range °F 20-200 Waterproof	\$31.00	16
555 Flex Fix	2	Metallic FlexFix Max Temp °F 210	\$12.00	36
555 Flex Fix	3	Metallic FlexFix Max Temp °F 210	\$18.00	24



Spin-In With Damper

Size (inches)	Net Each	Size (inches)	Net Each
6	\$4.80	12	\$7.40
7	\$5.75	14	\$9.60
8	\$6.20	15	\$24.00
9	\$6.70	16	\$24.00
10	\$6.80	18	\$28.00



Spin-In Take Offs: Model 702

For use with galvanized trunk duct

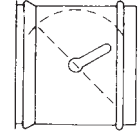

Spin-In With Scoop And Damper

Size (inches)	Net Each	Size (inches)	Net Each
6	\$6.60	12	\$11.05
7	\$7.60	14	\$16.50
8	\$8.40	15	\$31.00
9	\$8.45	16	\$31.00
10	\$9.60		



Spin-In Take Offs: Model 703

For use with galvanized trunk duct

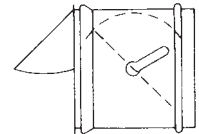

Starting Collars With Damper - Model 310 Starting Collars Without Damper - Model 261S

Size (inches)	Net Each (No Damper)	Size (inches)	Net Each (w/ Damper)
4	\$1.30	4	\$4.10
6	\$1.30	6	\$3.75
7	\$1.45	7	\$4.35
8	\$1.60	8	\$5.40
9	\$2.50	9	\$6.40
10	\$2.05	10	\$5.50
12	\$3.75	12	\$6.70
14	\$3.80	14	\$11.00
16	\$4.80	16	\$14.90
18	\$6.00	18	\$18.70
20	\$10.95		



Starting Collars

For use with sheet metal duct

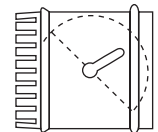

Size (inches)	Net Each	Size (inches)	Net Each
6 to 4	\$5.30	10 to 9	\$6.20
6 to 5	\$4.80	12 to 8	\$7.80
7 to 6	\$5.50	12 to 10	\$7.60
8 to 6	\$4.25	14 to 10	\$10.35
8 to 7	\$5.70	14 to 12	\$10.05
9 to 8	\$6.35	16 to 14	\$10.60
10 to 6	\$6.50	18 to 16	\$13.50
10 to 7	\$6.70	20 to 18	\$14.40
10 to 8	\$5.80		

Reducer: Model 265



**Gasket Stick-on Fittings:
with damper, for square duct - Model 168**



Size (inches)	Net Each
4	\$7.00
5	\$7.00
6	\$6.90
7	\$7.40
8	\$7.70
10	\$11.00
12	\$13.50
14	\$15.90
16	\$17.50
18	\$20.00
20	\$23.00

**2" DAMPER EXTENSIONS
FOR INSULATION.....\$2.25**

Damper Blade only - See page 45 for pricing

**Gasket Stick-on Fittings:
with damper, for round duct - Model 173**



Size (inches)	Net Each
4	\$7.90
5	\$7.90
6	\$6.90
7	\$8.50
8	\$9.40
10	\$11.50
12	\$16.00
14	\$17.00
16	\$23.00
18	\$34.00
20	\$38.00

**DAMPER EXTENSIONS
FOR INSULATION.....\$2.25**

Damper Blade only - See page 45 for pricing

Bullhead Wyes - Model 272



Size (inches)	Net Each
6x4x4	\$16.70
8x6x6	\$14.00
10x8x8	\$16.70
12x10x10	\$20.60
14x12x12	\$34.40
16x14x14	\$42.00
18x16x16	\$44.50

End Caps - Model 273



Size (inches)	Net Each
4	\$4.60
5	\$4.95
6	\$5.35
7	\$6.00
8	\$6.75
9	\$7.10
10	\$7.40
12	\$8.80
14	\$11.00
16	\$13.00
18	\$17.40
20	\$24.00

SNAP-LOCK PIPE, ELBOWS, REDUCERS & SQUARE TO ROUNDS



Size	Net Each	Size	Net Each
4"/26ga	\$8.70	**18"/26ga	\$23.95
5"/26ga	\$9.30	**20"/26ga	\$27.10
6"/26ga	\$10.30		
7"/26ga	\$12.30		
8"/26ga	\$14.00		
9"/26ga	\$15.40		
10"/26ga	\$16.90		
12"/26ga	\$19.00		
14"/26ga	\$22.70		
**16"/26ga	\$21.00		

Snap-Lock Pipe: 26 Gauge, 5' Lengths

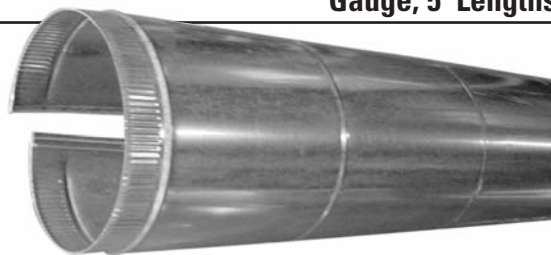

4" - 9" comes 10 pieces per bundle
10" - 20" comes 5 pieces per bundle

** 16", 18", 20" pipe comes in 4' lengths **

Size	Net Each	Size	Net Each
4"/26ga	\$2.10	14"/26ga	\$10.70
5"/26ga	\$2.60	16"/26ga	\$13.00
6"/26ga	\$3.10	18"/26ga	\$20.90
7"/26ga	\$4.60	20"/26ga	\$25.20
8"/26ga	\$4.50		
9"/26ga	\$5.60		
10"/26ga	\$6.20		
12"/26ga	\$7.90		

Elbows: 26 Gauge, 90°



Size (inches)	Net Each	Size (inches)	Net Each
6x6 to 6 rd.*/**	\$8.00	20x20 to 14 rd.**	\$20.00
8x8 to 8 rd.*	\$8.00	20x20 to 16 rd.**	\$20.00
9x9 to 6 rd.*	\$10.00	20x20 to 18 rd.**	\$20.00
9x9 to 8 rd.*/**	\$10.00	20x20 to 20 rd.**	\$20.00
9x9 to 9 rd.*/**	\$10.00	21x21 to 8 rd.***	\$19.00
10x10 to 6 rd.*	\$10.00	21x21 to 10 rd.***	\$19.00
10x10 to 8 rd.*	\$10.00	21x21 to 12 rd.***	\$19.00
10x10 to 10 rd.*	\$10.00	21x21 to 14 rd.***	\$19.00
12x12 to 8 rd.*	\$11.00	21x21 to 16 rd.***	\$19.00
12x12 to 10 rd.*/**	\$11.00	21x21 to 18 rd.***	\$19.00
12x12 to 12 rd.*/**	\$11.00	21x21 to 20 rd.***	\$19.00
14x14 to 14 rd.*	\$12.00	22x10 to 6 rd.***	\$19.00
15x15 to 10 rd.***/*	\$12.00	22x10 to 8 rd.***	\$19.00
15x15 to 12 rd.***/*	\$12.00	22x22 to 6 rd.***	\$20.00
15x15 to 14 rd.***/*	\$12.00	22x22 to 8 rd.***	\$20.00
16x16 to 16 rd.*	\$13.00	22x22 to 10 rd.***	\$20.00
18x18 to 14 rd.***/*	\$15.00	22x22 to 12 rd.***	\$20.00
18x18 to 16 rd.***/*	\$15.00	22x22 to 14 rd.***	\$20.00
20x20 to 8 rd.**	\$20.00	22x22 to 16 rd.***	\$20.00
20x20 to 10 rd.**	\$20.00	22x22 to 18 rd.***	\$20.00
20x20 to 12 rd.**	\$20.00	22x22 to 20 rd.***	\$20.00
		22x46 to ?? rd.****	\$44.00

Square to Round

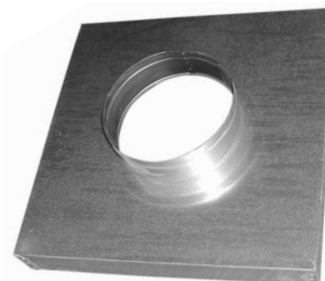

*3" High **6" High ***1½" High ****Price on 22/46 doesn't include round adaptor - field cut



Size (inches)	Tall Flashing	Cap	Storm Collar
4	\$16.90	\$8.50	\$3.10
6	\$22.20	\$10.30	\$4.20
8	\$35.00	\$13.40	\$5.60
10	\$65.90	\$35.40	\$12.40

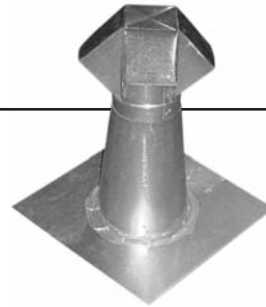

Vent Top Flashing

Combo Assembly

Size (inches)	Flashing & Cap Combos
4	\$22.30
6	\$31.40
8	\$36.60
10	\$47.40
12	\$57.60

Combo Assembly

- Cone spot welded to flashing/sealed w/silicone
- Cap collar assembly w/rivets
- Entire Assembly spot welded

Size (inches)	Net Each
A B C	
6 x 12 x 6 RD	\$20.05
6 x 12 x 8 RD	\$23.05
6.75 x 16 x 10 RD	\$35.80
8.5 x 18 x 12 RD	\$43.30
9.5 x 20 x 14 RD	\$49.50

High Efficiency Take Off With Damper & Gasket

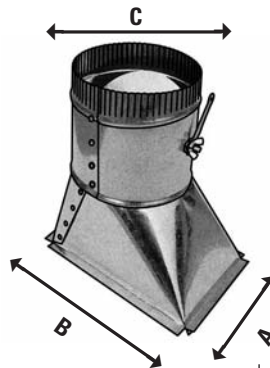

- **Gasket:** Fire Retardant polyethylene foam w/ double stick 3M tape UL94 HF - 1
- **Tabs:** 1" long - can be used with 1" - 1.5" ductboard or metal
- **Damper Hardware:** Standard Regulator
- **2" Damper Extension** for insulation - \$2.25

		Price Each
1)	#10 x 3/4" tech screws (self tapping) 1000 count	\$17.00
2)	#10 x 3/4" tech screws (self tapping) 6000 count	\$97.00
3)	1" Galvanized Hanging Strap 100' per box	\$14.00
4)	1 1/2" Galvanized Hanging Strap 100' per box	\$20.00
5)	Caddy Clamps Strap Hanger Clips MSR 24 50 per box	\$92.00
6)	Vent Fabric Quadrants for use with 1/2 rod	\$11.00
7)	Standing S-Lock 10'	\$11.00
8)	Flat S-Lock 10'	\$7.00
9)	2" Angle 10' (22 ga)	\$7.00
10)	Touch up Paint for Nailor Grilles (appliance white)	\$21.00
11)	Panduit Duct Straps 36" or 48" (50 per bag)	\$13-36" \$17-48"
12)	Panduit Gun	\$54.00
13)	Panduit Gun with Auto Cut Off	\$70.00
14)	3/8" Threaded Rod 10'	\$4.75
15)	Marco Strut 1 5/8" x 10' (14 ga)	\$19.00
16)	Marco 3/8" Flat Washer Pleated (100 per box)	\$5.50
17)	Marco 3/8" 16 Hex Nuts Pleated (100 per box)	\$5.50
18)	Fire Damper Fusible Links 165° or 212°	\$6.00
19)	Radiation Damper Fusible Links 165° or 212°	\$6.00
20)	Ductmate ModelTB Beam Clamp	\$3.25
21)	3/8" Beam "C" Clamp	\$1.50
22)	2" Brushes	\$1.10
23)	10'S Drive	\$4.50
24)	Round Duct Strap Bracket	\$3.50

Miscellaneous Items

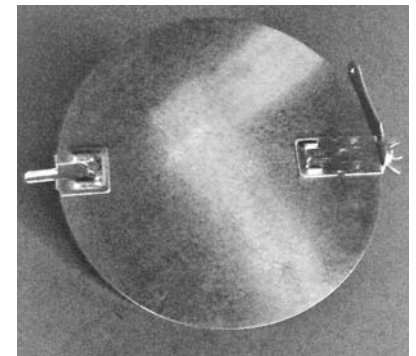

Model 275 Damper Blade

4"	\$2.65	12"	\$7.80
6"	\$3.40	14"	\$9.30
8"	\$4.20		
9"	\$5.40		
10"	\$6.50		

12	12" Folding Tool 3/8", 1/2"	LSC9G	9 1/2" Linemans Pliers
12F	12" Folding Tool 3/8", 1"	M12N	12" Aluminum Snip
12KH7	12" 7TPI Roughin Bi-Metal Blade	M12NRB	Replacement Blades for M12N
18	18" Rad. Divider	M14N	14" Aluminum Snip
18F	18" Folding Tool	M14NRB	Replacement Blades for M14N
24	24" Rad. Divider	MAXCG1	Max Grip, Left Cut
24F	24" Folding Tool	MAXCG2	Max Grip, Right Cut
4KH6	6" 6 Tpi Bi-Metal Roughin Blade-5	MAXCG3	Max Grip, Combo Cut +B29
4KH7	6" 7 Tpi Hi Carbon Roughin Blade	MAXCG5	Max Grip, Bulldog
4MC18	6" 18 Tpil Metal Cutting Blade-5p	MAXCG6	Max Grip, Offset, Left Cut
4MC24	6" 24 Tpil Metal Cutting Blade-5p	MAXCG7	Max Grip, Offset, Right Cut
9MC10	9L 10/14 Tpi Metal Cutting Blade	MB48A	Mini Brake, Single
AV1	AV1 Crew Snip Left	MBL	Mini Brake, Legs
AV2	AV2 Crew Snip Right	MC14N	14" Aluminum Combination SN
AV3	AV3 Crew Snip Combo	MC14NRB	Replacement Blades For MC14
AV6	AV6 Crew Snip Left O	MND10	5/16" Hollow Shaft Magnetic Nut Driver
AV7	AV7 Crew Snip Right	MND10S	Stubby 5/16" Hollow Shaft Nut Driver
BHE06	6" Bit Holder 4p	MND8	1/4" Hollow Shaft Magnetic Nut Driver
BHE10	10" Bit Holder 4	MND8S	Stubby 1/4" Hollow Shaft Nut Driver
C5	C5 Pipe Crimper 5 Blade	MSH14	1/4" Magnetic Hex Driver
CAW10G	Crew Wrench 10 Adj	MSH3/8	3/8" Magnetic Hex Driver
CAW12G	Crew Wrench 12 Adj	MSH516	5/16" Magnetic Hex Driver
CAW4G	Crew Wrench 4" Adj	MSHL14	1/4" Magnetic Hex Driver, Long
CAW6G	Crew Wrench 6" Adj	MSHL516	5/16" Magnetic Hex Driver, Long
CAW8G	Crew Wrench 8" Adj	N1	Hand Notcher
CB	Cutter Bit For HC1/HC2	RB400	Replacement Blade for TC400-6
CBAB	Breakaway Utility Blades 10/12	RH4V	12 OZ. Gripped Riveting Hammer
CBAUK	Breakaway Utility Knife	RRW3	Ratchet Wrench - Sq. Driver
CBB	Cutter Bit For HC1/HC2-5	RRW316	3/16" Ratchet Wrench Insert
CG10	Caulk Gun	RRW5	Ratchet Offset Wrench
CL9M	9" Torpedo Level w/Magnetic	RRW516	5/16" Ratchet Wrench Insert
CND10S	5/16" Nut Driver Stubby	RTC623	Ratchet Tube Cutter - 1/4" - 7/8"
CND8LM	1/4" Hex Driver Magnetic Long	RTC829	Ratchet Tube Cutter - 5/16"-11"
CND8M	1/4" Hex Driver Magnetic Standard	S2	3" Hand Seamer
CND8S	1/4" Nut Driver Stubby	S3	3" Offset Hand Seamer
CPL9M	9" Torpedo Level w/Magnetic	SH3V	18 oz. Setting Hammer
CPMT10	10" Multi Track Pliers	SL1	Snap Lock Punch
CPMT12	12" Multi Track Pliers	SL2	Snap Lock Punch, Forge
CPMT8	8" Multi Track Pliers	STKM	HVAC Starter Kit
CPNE9	9" Pliers New England S	ST1200	1/8" - 1 3/16" Tube Cutter
CPS33C	#1 Phillips Screwdriver	ST1500	1/4" - 1 5/8" Tube Cutter
CPS44C	#2 Phillips Screwdriver	ST600	1/8" - 5/8" Tube Cutter
CR18	Hand Riveter	ST900	1/8" - 1 1/8" Tube Cutter
CSS44C	4" Straight Screwdriver	ST96	Swaging Tool, 6 in 1 6 pk.
CSS56C	6" Straight Screwdriver	T416M	16' Tape - Magnetic Tip
DC 7G	7" Diagonal Cutting Pliers	T425M	25' Tape - Magnetic Tip
DE 3/16	3/16" Dbl End Drill Bit	T430M	30' Tape - Magnetic Tip
DE18	1/8" Dbl End Drill Bit	TB1	Soft Sided Tool Bag
DE30	#30 Dbl End Drill Bit	TC174	Big "IMP" Tube Cutter
DK4	Wood Handled Duct Board Knife	TC274	Heavy Duty Tube Cutter
DK6	Cushion Grip Knife	TC400	Tube Slicer / Cutter
DK6S	Cushion Grip Knife-Serr	TS1	Turbo Shear
DS1	Duct Stretcher	TS1RB	Turbo Shear Replacement
DS1C	Duct Stretcher Wheel	TSHD	Heavy Duty Turbo Shear
DS2	Offset Duct Stretcher	TY4G	Panduit Gun
FST2	Fin Straightening Tool	TY6	Panduit Gun, Auto Shut
HC1	Hole Cutter, to 12"	UBS5	Straight Utility Blade
HC1B	Pivot Pin for HC1 & HC2	W1-9	9 pc. Hex Key Set
HC2	Lrg Hole Cutter, To 20"	WSC1S	Cutter Stripper w/Spring
HW7X1/2ZG	7" X 1/2" Zip-In Bag/100 Screw	WSC8	Cutter, Crimper, Stripper
LNC7G	7 3/4" Long Nose Pliers	WT9SG	8 pc. 9" T-Handle Hex Key

DUCTMATE PROSEAL DUCT SEALER AND ACCESSORIES



Proseal Duct Sealer

Proseal is a premium quality high velocity water based duct sealant.

Special Characteristics:

- UL classified
- permanently flexible
- exceptional workability
- will not drip or sag
- low brush drag
- low shrinkage
- excellent adhesion to metal
- mild odor
- indoor or outdoor use
- superior sealing strength
- conforms to NFPA 90A & 90B
- mildew resistant

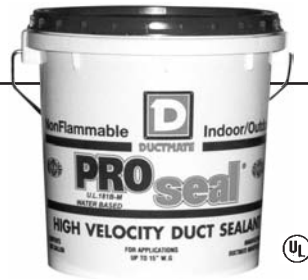

Item	Net Each
Proseal - 1 gallon pail	\$ 18.00

Proseal Duct Sealant applied to inorganic reinforced cement board:
 ▸ flame spread - 0
 ▸ smoke developed - 0

Item	Net
2" brushes	\$1.10 each

DuctMate Proseal meets LEEDS requirements.

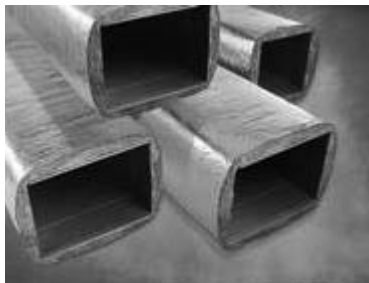

Knauf Friendly Feel® Duct Wrap with ECOSE® Technology sets a new industry benchmark for sustainable, high-performance, cost-effective insulation solutions.

- R6 Value

Sustainable Insulation Combination:

- Sand, one of the world's most abundant and renewable resources,
- Minimum 35% post-consumer recycled bottle glass and
- ECOSE Technology

Item	Net
2 ³ / ₁₆ " x 48" x75' roll	\$84.00



FRA & SRA SERIES SMALL ROOM FAN FORCED HEATERS

- BUILT-IN DISCONNECT SWITCH
- BUILT-IN THERMOSTAT
- AUTOMATIC FAN DELAY
- TAMPER PROOF FRONT COVER
- THREE PIECE CONSTRUCTION
- RECESSED OR SURFACE INSTALLATION
- DUAL RATING VOLTAGE
- NAVAJO WHITE BAKED ENAMEL FINISH



FILE # E21609

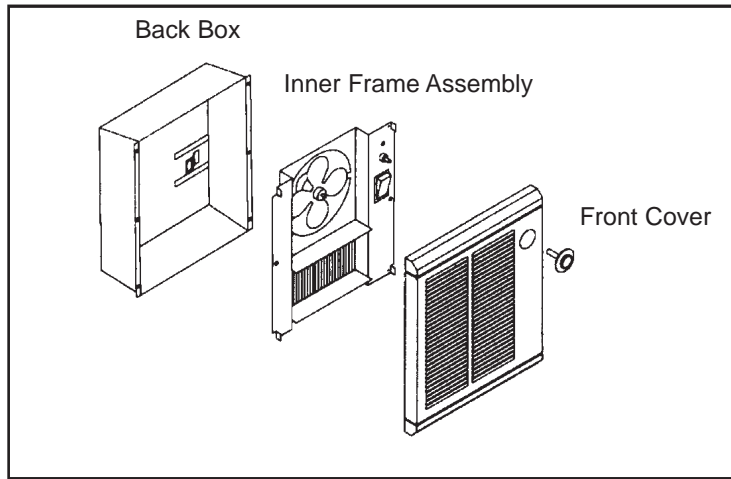

Model	Volts	KW	BTU/HR	Amps	Net Each	2" Wall Sleeve	Surface Mt. Box	Tamper Proof Cover
SRA1512DS	115	1500/750	5119/2560	12.5/6.3	\$264.00	\$41.00	\$41.00	\$25.00
SRA2020DS	208	2000/1000	6826/3413	9.6/4.8	\$264.00	\$41.00	\$41.00	\$25.00
SRA2024DS	240/208	2000/1500	6826/5119	8.4/7.2	\$264.00	\$41.00	\$41.00	\$25.00
FRA4024	240/208	4000/3000	13652/10239	16.7/14.5	\$386.00	\$65.00	\$63.00	\$46.00
FRA4824	240/208	4800/3600	16382/12287	20.0/17.3	\$386.00	\$65.00	\$63.00	\$46.00
SRA2027DS	277/240	2000/1500	6826/5119	7.2/6.3	\$264.00	\$41.00	\$41.00	\$25.00
FRA3027	277	3000/1500	10239/5120	10.8/5.4	\$386.00	\$65.00	\$63.00	\$46.00
FRA4027	277/240	4000/3000	13652/10239	14.5/12.5	\$386.00	\$65.00	\$63.00	\$46.00

• All heaters are single phase.

	W	H	D
Model FRA			
Rough-In Box:	14⁵/₁₆"	18¹/₄"	3³/₄"
Surface Mt. Box:	15³/₄"	19⁵/₁₆"	3³/₄"
Model SRA			
Rough-In Box:	9¹/₄"	11"	4"
Surface Mt. Box:	10⁵/₈"	12¹/₈"	4"



- Berko Model HUHAA Unit Heater for horizontal or vertical mounting
- Universal Voltage, KW, and phases on selected models
- Auto control delays fan action until heating element is warm
- Automatic reset linear thermal capillary
- Aluminum-finned, copper-clad steel sheath heating elements

Model	Volts	KW	Amps	PH	Standard Cont. Volt	HP	Net Each
HUHAA524	208/240	3.7/5.0	18.0/21.0	1-3	208/240	1/100	\$496.00
HUHAA724	208/240	5.6/7.5	27.0/31.3	1-3	24	1/30	\$764.00
HUHAA1024	208/240	7.5/10.0	36.0/42.0	1-3	24	1/30	\$824.00
HUHAA327	277	3	11	1	277	1/100	\$509.00
HUHAA527	277	5	18	1	277	1/100	\$525.00
HUHAA348	480	3	3.6	3	24	1/100	\$641.00
HUHAA548	480	5	6	3	24	1/100	\$693.00
HUHAA748	480	7.5	9	3	24	1/30	\$873.00
HUHAA1048	480	10	12	3	24	1/30	\$923.00

- 24-volt controls units are supplied with low voltage control transformer and contactors except 3-5 KW and 277 & 208/240
- Single and three phase wiring on dual phase units are field interchangeable
- No disconnect

ACCESSORIES

Model	For Use With	Description	Net Each
HUHAB10	3KW to 10KW units	wall or ceiling bracket	\$63.00
HVDMB5	3KW and 5KW units	vertical bracket	\$65.00
HVDMB20	7.5 & 10	vertical bracket	\$99.00
HUHAAMT1	all except 5KW 3PH	single pole field installed	\$90.00
T8775A1009	24 volt units	low voltage t'stat	\$74.00
M602W	3 phase heaters	line voltage t'stat	\$40.00
M601W	1 phase heater	line voltage t'stat	\$28.00
HUHAAMT2	5KW 3 phase	2 stage field installed	\$134.00
HUHAADS25	277/460	disconnect - 25 amps	\$148.00
HUHAADS60	208/3 phase only	disconnect - 60 amps	\$206.00

Honeywell E3 Point Gas Detection System and Accessories:

Model # E3SA/E3SAH: 24v/120v Stand Alone Detector

E3 Point Sensors:

- O2 - Oxygen
- H2 - Hydrogen
- CH4 - Methane
- NO2 - Nitrogen Dioxide
- CO - Carbon Monoxide

Sensor Cartridge: E3SRMNO2 (Remote)

Accessories:

- Model 301AP Annunciator Panel
- Model 301C Controller
- Model 301C-DLC Controller w/ data logger
- Model 301CEM Controller (Refridg Detector) w/ horn and strobe
- Model E3 PTCAGE Sensor Cover



**** Contact Sales for current pricing ****

CO2/ Temp sensors

- Model IAQDAC Duct Mount w/ display and relay
- Model IAQWAC Wall Mount w/ display and relay

Refrigerant Detectors w/ Horn and Strobe

- Model R123 Refrigerant Sensor
- Model R134A Refrigerant Sensor

AIR FLOW MEASURING INSTRUMENTS

System Pressure Testing for Leaks

United Sheet Metal Leakage Test Kits

Size	Net Each
100 CFM Test Kit (small)	\$2035.00
250 CFM Test Kit (large)	\$2640.00

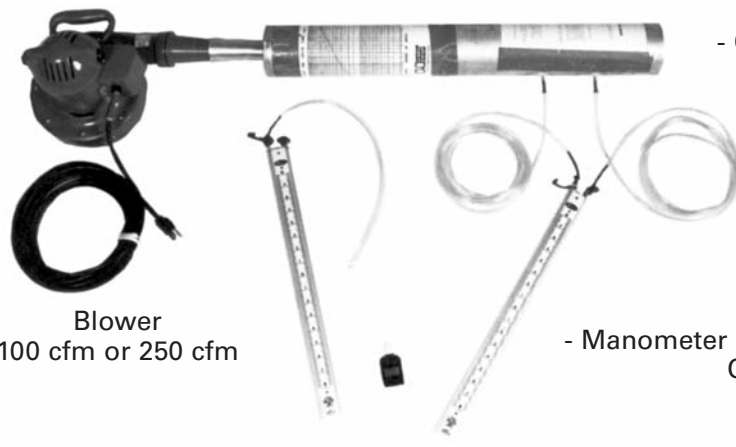

Blower
100 cfm or 250 cfm

- Orifice Tube: 4" Small test kit
5" Large test kit

- Tubing 3/8" Inner dimension
1/2" Outer dimension

- Manometer and fluorescein concentrate
Qty. of 2

REZNOR UDAP UNIT HEATER STOCK PRICE SHEET



HAHN-MASON AIR SYSTEMS, INC.



Reznor's V3 Series UDAP high efficiency heaters are excellent for space heating applications. These gas-fired unit heaters are power vented in order to eliminate heat losses up the flue pipe. Power vented models have a higher initial cost than similar "gravity" vented models, but will save money on fuel costs. UDAP heaters are designed for 82-83% thermal efficiency. All Reznor V3 series heaters are CSA Design Certified, and have a refreshing appearance with a glossy white cabinet finish.

Model	Description	Net Price
UDAP-30	30MBH Power Vented Unit	\$670.00
UDAP-45	45MBH Power Vented Unit	\$697.00
UDAP-60	60MBH Power Vented Unit	\$739.00
UDAP-75	75MBH Power Vented Unit	\$767.00
UDAP-100	100MBH Power Vented Unit	\$880.00
UDAP-125	125MBH Power Vented Unit	\$993.00
UDAP-150	150MBH Power Vented Unit	\$1057.00
UDAP-175	175MBH Power Vented Unit	\$1173.00
UDAP-200	200MBH Power Vented Unit	\$1260.00
UDAP-250	250MBH Power Vented Unit	\$1409.00
UDAP-300	300MBH Power Vented Unit	\$1686.00
UDAP-400	400MBH Power Vented Unit	\$2061.00
VENT CAP 4	Vertical 4" Vent Cap UDAP30-125	\$33.00
VENT CAP 5	Vertical 5" Vent Cap UDAP150-250	\$39.00
VENT CAP 6	Vertical 6" Vent Cap UDAP300-400	\$62.00
Conversion Kit	Converts from Natural Gas to Propane	\$75.00
24v T-Stat	Honeywell Model #T812C1000	\$28.00

Hahn-Mason represents the entire REZNOR line including, Unit Heaters, Air Handlers, Duct Furnaces, Direct Fired, Gas Radiant, Air Curtains, Energy Recovery, Green Energy Heating, Destratification, Condensers, Packaged Air Conditioning, Packaged Makeup Air Units, and Electric Heat.



***** DISCONTINUED WAREHOUSE ITEMS*****

- ⤴ FIRE RATED PLENUM SLOT DIFFUSER: NAILOR MODEL 5575 SUPPLY WITH 3/4" SLOT WIDTH - 2' X 2SLOT W/8" INLET

- ⤴ DUAL DUCT TERMINAL UNIT: NAILOR MODEL P3230 (PNEUMATIC) 4"/10"/12" INLET SIZES

- ⤴ ALUMINUM EGGCRATE CORE ONLY 48" x 24"

- ⤴ NAILOR STATIC FIRE DAMPERS: PLEASE CALL HMI WAREHOUSE FOR AVAILABLE SIZES

***** CONTACT HMI FOR PRICING AND AVAILABILITY*****



Home Office & Warehouse

Charlotte, NC

4901 Dwight Evans Road
Suite 120
Charlotte, NC 28217
[704] 523-5000 *phone*
[704] 523-5171 *fax*
[704] 523-5344 *warehouse phone*
[704] 523-5880 *warehouse fax*

Regional Offices

Raleigh, NC

1001 Wade Ave.
Suite 205
Raleigh, NC 27605
[919] 834-9230 *phone*
[919] 831-9714 *fax*

Asheville, NC

1796 Hendersonville Road
Suite S
Asheville, NC 28803
[828] 277-1544 *phone*
[828] 277-1564 *fax*

Charleston, SC

85A Paradise Point
Summerville, SC 29485
[843] 871-2493 *phone*
[843] 871-2510 *fax*

Columbia, SC

2330 Main Street
Columbia, SC 29201
[803] 978-2038 *phone*
[803] 978-2039 *fax*

Greensboro, NC

2915 Baltic Avenue
Greensboro, NC 27406
[336] 272-9198 *phone*
[336] 272-9299 *fax*

Greenville, SC

112 South Main Street
Suite E
Greer, SC 29651
[864] 655-5980 *phone*
[864] 655-5982 *fax*

Hickory, NC

511 S. Main Ave.
Newton, NC 28645
[828] 726-2412 *phone*
[828] 994-4249 *fax*

www.hahn-mason.com



HAHN-MASON
AIR SYSTEMS